

# technostar®

GIDA VE PAKETLEME MAKİNALARI  
FOOD PROCESSING AND PACKAGING MACHINERY

"WE ADDED  
CONFIDENCE TO  
TECHNOLOGY"

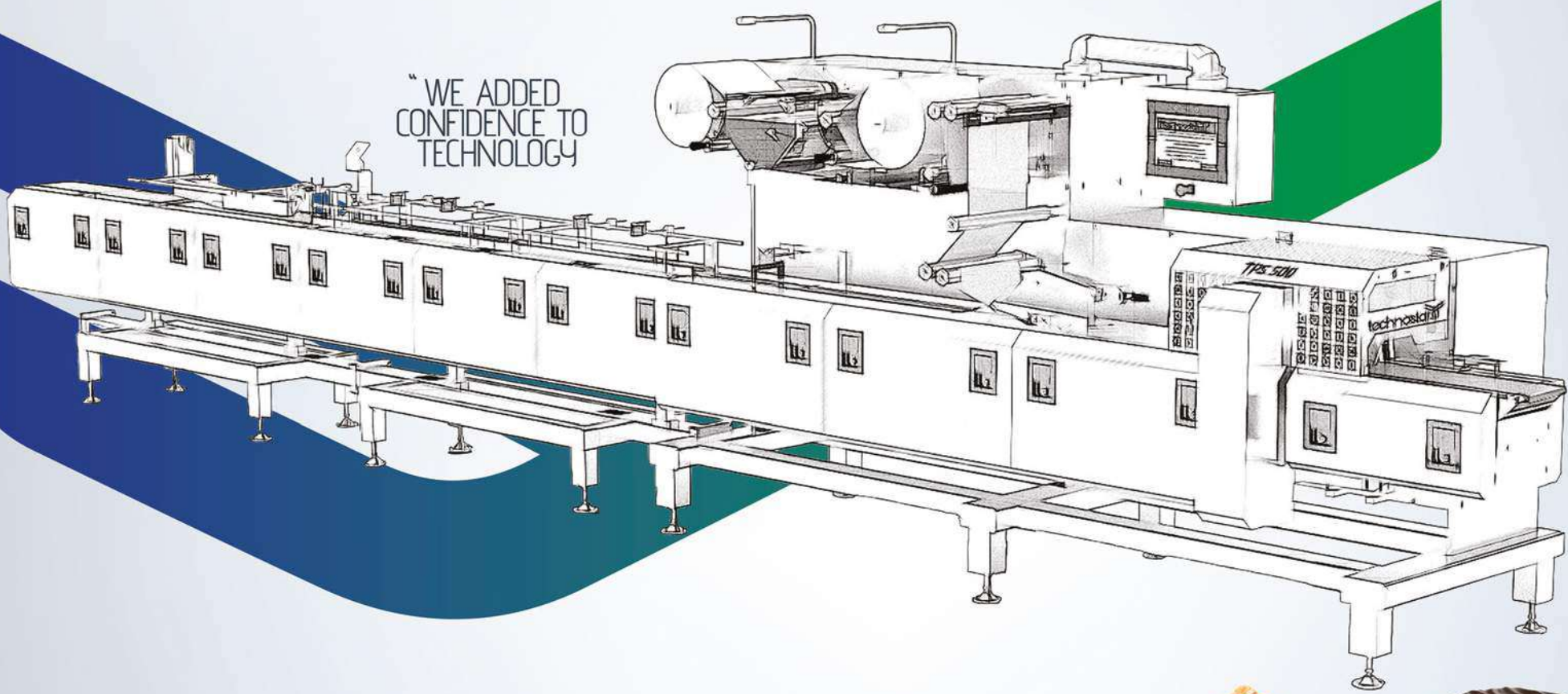

## ÜRÜN KATALOĞU

PRODUCT CATALOGUE

[technostarmachine.com](http://technostarmachine.com)



# HAKKIMIZDA



TECHNO STAR MAKİNA, KIRŞEHİR Organize Sanayi Bölgesinde 6.000 m<sup>2</sup>lik kapalı alanda Gıda ve paketlenme makinaları imalatı yapmaktadır. Şirketimiz, tasarım, tedarik, kurulum ve satış sonrası hizmetler dahil olmak üzere eksiksiz çözümler sunarak tüm dünya pazarlarına hizmet vermektedir. Sektörünün ihtiyacı olan makinaları TÜV CERT DIN EN ISO 9001-2000 kalite yönetim sistemi ile Avrupa standartlarındaki üretimi ile yurt içi ve yurt dışı pazarlarda rağbet görmüş olan makinaların üretim programında yer alan makinalarla kombine tesisler kurabildiği gibi kurulu tesislerin ihtiyacı olan makinaları da en kısa sürede teslim edip montaj ve servis ekibiyle hizmet vermektedir. Üretimde sektörün öncü firmaları arasında TECHNO STAR markası ile girmeyi başaran firmamız kısa sürede ihracatta da hızlı bir yükseliş gerçekleştirmiştir. Kalite ve satış sonrası hizmetlerde güven veren firmamızın gelişim sürecindeki başarısında en önemli etken inovasyona verdiğimiz önemdir. 52 ülkeye yapmış olduğu ihracatı ile kalite standardı ve servis hizmeti ile kabul görmüş, yeni hedef ülkelerle ilgili çalışmalarına da yoğunluk vermiştir. Sektöre özel deneyimli yöneticiler, Ar-Ge, üretim ve satış sonrası departmanlarda çalışan yüksek nitelikli mühendisler ile hedefimiz, yüksek standartlarda makinalar uygulayarak ve müşterilerimize "amaça uygun" çözümler sunarak dünya pazarlarında liderlerden biri olmaktır.

TECHNO STAR MAKİNA, üstün üretim kabiliyeti ve insan faktörünü parça imalatında ortadan kaldırarak, yüksek hassasiyetli üretim hedefi sayesinde sektöründe ki eş değer firmalardan bir adım öndedir. Makina parkurunda bulunan CNC tezgahlar sayesinde hızlı ve kaliteli üretim kabiliyetine sahiptir. 7 adet CNC tezgah, lazer kesim, abkant büküm makinasını bünyesinde bulundurarak her türlü parça imalatını kendi başına yapabilen bir kurumdur. Bu durum hizmet verdiği kurumların talepleri doğrultusunda üretimi çeşitlendirme becerisini kuruma katmıştır. Kendi geliştirdiği üretim yöntemleri, üstün mühendislik gücü ve deneyimli uzman kadrosu ile üretimde sağladığı kalite ve sürdürdüğü araştırma ve geliştirme çalışmaları itibarı ile sektöründe tasarım ve üretim yönünden liderlik konumunu kazanmıştır. TECHNO STAR MAKİNA, endüstriyel yatırımlar için yaptığı üretimini, geniş bilgi birikimi ve tasarımları ile pekiştirmiştir. Kuruluşundan bu yana firmamızın felsefesi, kendi tasarımı ve üretim yöntemlerini geliştirerek, iç ve dış pazarda kaliteli, güvenilir ve rekabetçi yerini korumak ve geliştirmek olmuştur. Kalite ve satış sonrası hizmeti daima ön planda tutmaktadır. Ayrıca, şirketimizin uzun vadeli başarısı için bir diğer önemli gereklilik özel çalışanlarımız ve onların müşterilerimizi memnun etme taahhütleridir. Müşterilerimizin hizmetlerimize ihtiyaç duydukları her zaman ve her yerde tamamen emrindeyiz.

## INFORMATION D'ENTREPRISE

TECHNO STAR MAKİNA fabrique des lignes de production alimentaires et d'emballage dans une zone fermée de 6 000 m<sup>2</sup> implantée a la zone industrielle de KIRSEHIR. Notre société dessert tous les marchés mondiaux en fournissant des solutions complètes comprenant la conception, la fourniture, l'installation et les services après-vente. Elle peut établir des installations combinées avec les machines de ce secteur selon le besoin, avec les machines de production demandées sur les marchés nationaux et étrangers. Ces machines sont fabriquées aux normes européennes avec le système de gestion et de la qualité TÜV CERT DIN EN ISO 9001-2000 , ainsi que livrer dans les plus brefs délais les installations nécessaire et mises en service avec son équipe de montage. Notre entreprise, qui a réussi à entrer dans l'une des entreprises leaders du secteur en production avec sa marque TECHNO STAR, a réalisé une augmentation rapide de ses exportations. Le facteur le plus important du succès de notre entreprise est l'importance que nous accordons à l'innovation, donnant une confiance dans la qualité et le service après-

vente, Avec ses exportations dans 52 pays, elle a été acceptée avec ses standards de qualité et de service et a concentré son travail sur de nouveaux pays. Notre objectif est d'être l'un des leaders sur les marchés mondiaux, en appliquant des machines de haut niveau et en offrant des solutions adaptées à nos clients avec un personnel expérimenté spécifique à l'industrie et des ingénieurs hautement qualifiés travaillant dans la R&D, la production et le service après-vente. TECHNO STAR MAKİNA a une longueur d'avance sur les entreprises équivalentes du secteur grâce à sa capacité de production supérieure et à son objectif de production de haute précision en éliminant le facteur humain dans la fabrication des pièces. Grâce aux stations d'usinage CNC du parc de machines, elle a la capacité de produire rapidement et d'une qualité supérieure. C'est une institution qui peut fabriquer toutes sortes de pièces par elle-même en intégrant 7 stations de CNC, des découpes laser et des presses plieuses. Cela a permis d'ajouter la possibilité de diversifier la production en fonction des demandes. Elle a acquis une position de

leader dans le secteur en termes de conception et de production grâce aux méthodes qu'elle a développées, avec sa puissance d'ingénierie supérieure, son personnel expérimenté, sa qualité fournie dans la production et aux études de recherche et développement. TECHNO STAR MAKİNA a renforcé sa production pour les investissements industriels grâce à ses vastes connaissances et conceptions. La philosophie de notre entreprise depuis sa création a été de maintenir et de développer sa position de qualité, fiable et compétitive sur les marchés nationaux et étrangers en utilisant ses propres méthodes de conception et de production en privilégiant toujours la qualité et le service après-vente. De plus, une autre exigence importante pour le succès à long terme de notre entreprise est nos employés et leur engagement à satisfaire nos clients. Nous sommes entièrement à votre disposition quand et où nos clients ont besoin de nos services.

## О НАС

ТЕХНО СТАР МАКИНА занимается производством пищевой и упаковочной техники в закрытом помещении площадью 6000 м<sup>2</sup> в организованной промышленной зоне КЫРШЕХИРА. Наша компания обслуживает все мировые рынки, предоставляя комплексные решения, включая проектирование, поставку, установку и послепродажное обслуживание. Компания имеет возможность создавать комбинированные предприятия с оборудованием, пользующимся спросом на внутреннем и внешнем рынках, производимым по европейским стандартам с системой управления качеством TÜV CERT DIN EN ISO 9001-2000., а также в кратчайшие сроки поставлять отдельные машины, необходимые действующим объектам, обеспечивая их сервис своей монтажной и сервисной бригадой. Наша компания, которой удалось войти в число ведущих компаний сектора по производству под брендом TECHNO STAR, за короткое время добилась быстрого увеличения экспорта. Важнейшим фактором успеха нашей компании, дающим уверенность в качестве и послепродажном обслуживании, является значение, которое мы придаем инновациям.

Благодаря стандартам качества и обслуживания компания экспортирует продукцию в 52 страны мира и сосредотачивает свою работу на новых целевых странах. Наша цель – быть одним из лидеров на мировых рынках, применяя высококачественное оборудование и предлагая нашим клиентам «целесообразные» решения, с опытными менеджерами и высококвалифицированными инженерами, работающими в отделах исследований и разработок, производства и послепродажного обслуживания. TECHNO STAR MAKİNA на шаг впереди аналогичных компаний в этой отрасли благодаря своим превосходным производственным возможностям и высокой точности производства за счет исключения человеческого фактора при производстве деталей. Благодаря станкам с ЧПУ в машинном парке, обеспечивается быстрое и качественное производство. Это предприятие, которое может самостоятельно производить широкий ассортимент продукции, используя 7 станков с ЧПУ, станки для лазерной резки и листогибочные прессы. За счет этого оборудования имеется возможность диверсифицировать производство в соответствии с потребностями

производителей, которые находятся на обслуживании компании. Благодаря проектированию, собственным разработанным методам производства, качеству производства, превосходной инженерной мощи и опытному экспертному персоналу, а также не прекращающимся исследованиям и разработкам, компания завоевала лидирующие позиции в отрасли. TECHNO STAR MAKİNA укрепила свое производство для промышленных инвестиций своими обширными знаниями и проектами. Философия нашей компании с момента ее основания, разрабатывая собственные методы проектирования и производства, заключалась в поддержке и развитии ее качественного, надежного и конкурентного места на внутреннем и внешнем рынках. Качество и послепродажное обслуживание всегда в приоритете. Кроме того, еще одним важным требованием для долгосрочного успеха нашей компании является стремление удовлетворить потребности наших сотрудников и наших клиентов. Мы полностью в распоряжении наших клиентов, когда и где бы они ни нуждались в наших услугах.

## ABOUT US

TECHNO STAR MAKİNA manufactures food and packaging machinery in a closed area of 6,000 m<sup>2</sup> in KIRŞEHİR Organized Industrial Zone. Our company serves all world markets by providing complete solutions including design, supply, installation and after-sales services. It can establish combined facilities with the machines that the sector needs, with the machines of the production program of the machines demanded in the domestic and foreign markets with their production to European standards with the quality management system TÜV CERT DIN EN ISO 9001-2000, as well as delivering the necessary machines to established facilities as soon as possible, provides service with its assembly and service team. Our company, which succeeded to enter one of the leading companies of the sector in production with the brand TECHNO STAR, achieved a rapid increase in exports in a short time. The most important factor in the success of our company, which gives confidence in quality and after-sales services,

is the importance we attach to innovation.

With its exports to 52 countries, it has been accepted with its quality standards and service, and has focused on its work on new target countries. Our goal is to be one of the leaders in the world markets, by applying top level machinery and offering "fit for purpose" solutions to our customers, with experienced industry-specific managers and highly qualified engineers working in R&D, production and after-sales services. TECHNO STAR MAKİNA is one step ahead of the equivalent companies in the sector thanks to its superior production capability and high precision production target by eliminating the human factor in the manufacturing of parts. Thanks to the CNC processing stations in the machine park, it has the ability to produce fast and high quality. It is an institution that can manufacture all kinds of parts on its own by incorporating 7 CNC processing stations, laser cutting, and press brake bending machines. This situation has added the ability to diversify production in line with the

demands of the institutions it serves. It has gained a leadership position in the sector in terms of design and production, thanks to the production methods it has developed, its superior engineering power and experienced expert staff, the quality it provides in production and the research and development studies it continues. TECHNO STAR MAKİNA has reinforced its production for industrial investments with its extensive knowledge and designs. The philosophy of our company since its establishment has been to maintain and develop its quality, reliable and competitive position in the domestic and foreign markets by developing its own design and production methods. It always prioritizes quality and after-sales service. In addition, another important requirement for the long-term success of our company is our employees and their commitment to satisfy our customers. We are completely at your disposal whenever and wherever our clients need our services.

تقوم شركة تانكو ستار ماكينة، بتصنيع آلات المواد الغذائية والتعبئة والتغليف في منطقة مغلقة تبلغ مساحتها 6.000 متر مربع في المنطقة الصناعية المنظمة في كيشهير تخدم شركتنا جميع الأسواق العالمية من خلال تقديم حلول كاملة بما في ذلك التصميم والتوريد والتكريب وخدمات ما بعد البيع TÜV يمكنك إنشاء مرافق مشتركة مع الآلات في برنامج إنتاج الآلات المطلوبة في الأسواق المحلية والأجنبية مع إنتاج الآلات التي يحتاجها القطاع ، مع نظام إدارة الجودة و المعايير الأوروبية. كما تقوم بتوصيل الآلات التي تحتاجها المرافق المنشأة في أسرع وقت ممكن وتوفر الخدمة مع فريق التجميع CERT DIN EN ISO 9001-2000 والخدمة زيادة سريعة في الصادرات في وقت قصير. أهم ، TECHNO STAR حققت شركتنا ، التي نجحت في دخول إحدى الشركات الرائدة في القطاع في الإنتاج بالعلامة التجارية عامل في نجاح شركتنا ، والذي يعطي الثقة في الجودة وخدمات ما بعد البيع ، هو الأهمية التي نوليها للابتكار مع صادراتها إلى 52 دولة ، تم قبولها بمعايير الجودة والخدمة ، وركزت على عملها في البلدان المستهدفة الجديدة هدفنا هو أن يكون لدينا مديري ذوي خبرة في قطاع معين ، ومهندسين مؤهلين تأهيلا عاليا يعملون في أقسام البحث والتطوير والإنتاج وما بعد البيع ، أن تكون أحد رواد الأسواق العالمية من خلال تطبيق معايير عالية من الآلات وتقديم حلول "مناسبة للغرض" لعملائنا

تتقدم تانكو ستار ماكينة بخطة واحدة على الشركات المماثلة في هذا القطاع بفضل قدرتها الإنتاجية الفائقة وهدف الإنتاج عالي الدقة من خلال القضاء على العامل في ساحة الماكينات ، لديها القدرة على إنتاج جودة عالية وسريعة. إنها مؤسسة يمكنها تصنيع جميع أنواع الأجزاء بمفردها CNC البشري في تصنيع الأجزاء. بفضل مقاعد والآلات كاستيب بالليزر ، والآلات التي الفرامل. لقد أضاف هذا الوضع القدرة على تنوع الإنتاج بما يتماشى مع متطلبات المؤسسات التي يخدمها. ، CNC من خلال دمج 7 مقاعد لقد اكتسبت مكانة ريادية في هذا القطاع من حيث التصميم والإنتاج ، وذلك بفضل أساليب الإنتاج التي طورتها ، وقوتها الهندسية الفائقة وموظفيها ذوي الخبرة ، والجودة التي توفرها في الإنتاج ودراسات البحث والتطوير التي تواصلها عززت تانكو ستار ماكينة إنتاجها للاستثمارات الصناعية بمعرفتها وتصميماتها الواسعة. كانت فلسفة شركتنا منذ إنشائها هي الحفاظ على الجودة والموثوقية والمكانة التنافسية وتطويرها في الأسواق المحلية والأجنبية من خلال تطوير أساليب التصميم والإنتاج الخاصة بها. إنه يعطي الأولوية دائمًا للجودة وخدمة ما بعد البيع. بالإضافة إلى ذلك ، هناك مطلب مهم آخر لنجاح شركتنا على المدى الطويل وهو موظفينا والتزامهم بإرضاء عملائنا نحن تحت تصرفك تمامًا متى وأينما يحتاج عملائنا إلى خدماتنا

## معلومات عنا

# İÇİNDEKİLER INDEX

**technostar**  
GIDA VE PAKETLEME MAKİNALARI  
FOOD PROCESSING AND PACKAGING MACHINERY



CONTENU

СОДЕРЖАНИЕ

المحتويات



**YATAY PAKETLEME MAKİNALARI** 04-13  
• Horizontal packaging machine  
• Machine d'emballage horizontale  
• Горизонтальные упаковочные машины  
• آلات التغليف الأفقية



**ZARF TİPİ PAKETLEME MAKİNALARI** 14-15  
• X fold type packaging machine  
• Machine d'emballage type plieuse en x  
• Упаковочные машины конвертного типа  
• آلات التغليف من النوع المغلف



**BİSKÜVİ KREMALAMA MAKİNALARI** 16-19  
• Biscuit creaming & sandwiching machine  
• Machine cremeuse pour biscuits  
• Машины для печенья с начинкой  
• ماكينات صنع البسكويت



**PUDRA ŞEKERİ DEĞİRMEN MAKİNALARI** 20  
• Powder sugar mill  
• Moulin a sucre en poudre  
• Мельницы для сахарной пудры  
• آلات طحن مسحوق السكر

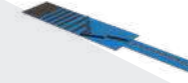

**BESLEME SİSTEMLERİ** 21  
• Feeding system  
• Systemes d'alimentation  
• Системы автоматической подачи продукта  
• أنظمة التغذية



**DİKEY PAKETLEME MAKİNALARI** 22-33  
• Vertical packaging machine  
• Machines d'emballage verticales  
• Вертикальные упаковочные машины  
• ماكينات التعبئة والتغليف العمودية



**DİKEY PAKETLEME MAKİNALARI** 34-35  
(Yardımcı Ekipmanlar)  
• Vertical packaging machine auxiliary equipments  
• Equipements auxiliaires pour machines d'emballage verticales  
• Вертикальные упаковочные машины (вспомогательное оборудование)  
• آلات التغليف العمودية (المعدات المساعدة)



**GOFRET ÜRETİM HATTI** 36  
• Wafer production line  
• Ligne de production de gaufrettes  
• Линия производства вафель  
• خط إنتاج بسكويت الويفر



**GOFRET ÜRETİM HATTI EKİPMANLARI** 37-42  
• Wafer production line equipments  
• Equipements pour ligne de production de gaufrettes  
• Оборудование для производства вафель  
• معدات خط إنتاج ويفر



**TAHİL BAR ÜRETİM HATTI** 43  
• Cereal bars production line  
• Ligne de production de barres cereales  
• Линия производства зерновых батончиков  
• خط إنتاج الحبوب



**NUGA KAREMEL – KROKANT HATTI** 44  
• Nougat caramel-croquant production line  
• Ligne de production de nougats caramel et croquants  
• Линия производства зрльяжа  
• خط إنتاج نوجا كروكان



**MARSHMALLOW ÜRETİM HATTI** 45  
• Marshmallow production line  
• Ligne de production de marshmallow  
• Линия производства зефира  
• خط إنتاج مارشميلو



**TAHİL BAR/ NUGA/MARSHMALLOW ÜRETİM HATTI EKİPMANLARI** 46-56  
• Cereal bars / nougat caramel / Marshmallow production line equipments  
• Equipements pour ligne de production barres cereales – nougats caramel /croquants – marshmallow  
• Оборудование производственной линии зерновых батончиков/нуга/зефира  
• معدات خط إنتاج بار الحبوب / نوجا / مارشميلو



**ÇİKOLATA MUTFAĞI EKİPMANLARI** 57-59  
• Chocolate kitchen equipments  
• Equipement cuisine pour chocolat  
• Оборудование для шоколадной кухни  
• معدات مطبخ الشوكولاته



**MARSHMALLOW MUTFAĞI EKİPMANLARI** 60-64  
• Marshmallow kitchen equipments  
• Equipement cuisine pour marshmallow  
• Оборудование для зефирной кухни  
• معدات مطبخ مارشميلو

## MOPA

MOPA ( CONVEYOR PRODUCT DISTRIBUTION SYSTEM )  
MOPA (SYSTEME DE DISTRIBUTION DE PRODUITS PAR CONVOYEUR)  
MOPA  
موبا

technostar

## MOPA



### ÜRÜN ÖZELLİKLERİ

Çoklu paketleme makinasının kullanılması gerektiği imalatlarda üretim kolaylığı sağlamak için tasarlanmıştır. Mopa sistemi, hattan gelen ürünlerin klepe sistemi aracılığıyla paketleme makinasına yönlendirilmesini sağlar. Ayrıca paketleme makinanızda arıza oluşması durumunda mopanın son konveyör bant sisteminde ürünler arıza çözümleninceye kadar istiflenebilmektedir. Arızanın sonlandırılmasıyla ürünler paketleme makinasına otomatik yönlendirmekte ve paketleme işleminiz gerçekleştirilmektedir. Paketleme makinamız ve mopa sistemi entegre çalışmaktadır.

### TEKNİK VERİLER

- Çoklu paketleme makinaları için idealdir.
- 9 adet servo motor kullanılmaktadır. (2 adet paketleme makinasının besleme sistemi için kullanılan servo motor sayısıdır.)

### PRODUCT FEATURES

It is designed to provide ease of production in manufacturing where multiple packaging machines are required. The Mopa system ensures that the products coming from the line are directed to the packaging machine through the clamp system. In addition, in case of a malfunction in your packaging machine, the products can be stacked in the last conveyor belt system of the mop until the malfunction is resolved. With the termination of the fault, the products are automatically directed to the packaging machine and your packaging process is carried out. Our packaging machine and mopa system work integrated.

### TECHNICAL DATA

- Ideal for multiple packaging machines.
- 9 servo motors are used. (It is the number of servo motors used for the feeding system of 2 packaging machines.)

## TPS 500

technostar

TPS 500-İNLINE HIZLI PAKETLEME MAKİNASI  
TPS 500 - INLINE SPEED PACKAGING MACHINE  
TPS 500 - MACHINE D'EMBALLAGE RAPIDE EN LIGNE  
ЛИНЕЙНАЯ БЫСТРАЯ УПАКОВОЧНАЯ МАШИНА TPS 500  
ماكينة تعبئة السريع TPS 500

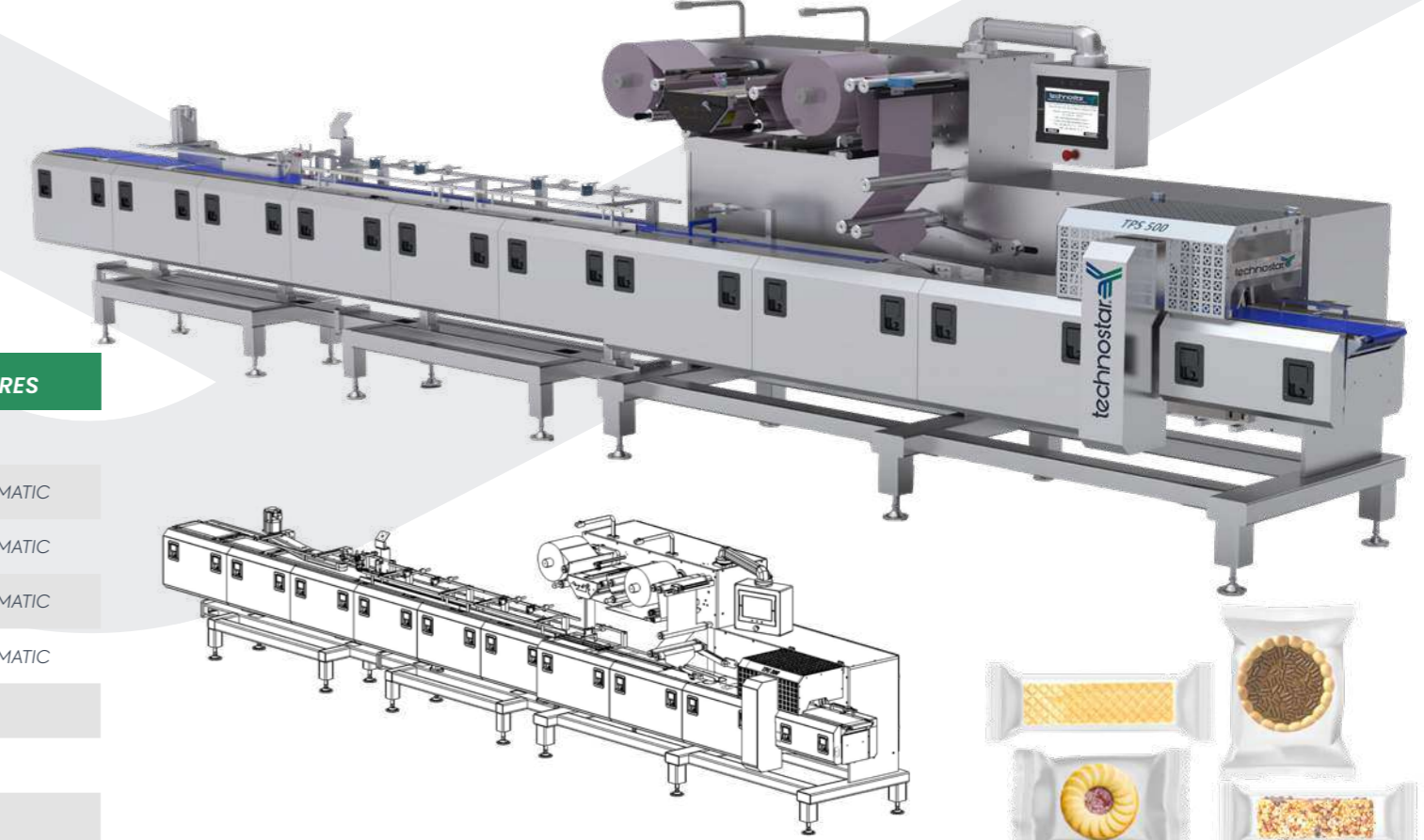

### TEKNİK ÖZELLİKLER / TECHNICAL FEATURES

VOLTAJ VOLTAGE	400 V + N + PE
BOBİN GRUBU BOBBINE GROUP	OTOMATİK / AUTOMATIC
ÜRÜN TAŞIMA SENKRONU PRODUCT TRANSPORT SYNCHRON	OTOMATİK / AUTOMATIC
ÇENE BEKLEME AYARI JAW WAITING ADJUSTMENT	OTOMATİK / AUTOMATIC
FOTOSEL AYARI PHOTOCELL ADJUSTMENT	OTOMATİK / AUTOMATIC
FREKANS FREQUENCY	50-60 Hz
ŞASE CHASSIS	7075(AIZnCu1,5)
DİSK GRUBU DISC GROUP	4 ADET / 4 PCS
OPERATÖR EKRAN OPERATOR SCREEN	RENKLİ DOKUNMATİK 12" COLOR TOUCH SCREEN 12"
YAPIŞTIRMA ÖZELLİĞİ ADHESIVE FEATURE	SOĞUK+SICAK / COLD + HOT
BESLEME TİPİ FEEDING TYPE	İN-LİNE
KAPASİTE CAPACITY	500 PAKET / DKK 500 PACK / MIN
TOPLAM KURULU GÜÇ TOTAL INSTALLED POWER	28 kW
SERVO SAYISI NUMBER OF SERVO MOTOR	14

### ÜRÜN ÖZELLİKLERİ

Farklı boyutlarda ürünleri müşterinin istekleri dikkate alınarak besleme bandına aktaran ve e-motion kontrol sistemiyle paketlemesini sağlayarak uzun süre muhafaza edilmesine olanak sağlayan mekanizmaların bütünüdür. Makine tekli ürün paketlemesine uygun olarak tasarlanmıştır. Ürünler konveyör bantlar ve askerler vasıtasıyla akarken paketlemeden sonra hazır hale getirilir.

### PRODUCT FEATURES

It is the whole of the mechanisms that transfer the products of different sizes to the feeding belt, taking into account the wishes of the customer, and enable them to be stored for a long time by packaging them with the e-motion control system. The machine is designed for single product packaging. Products are made ready after packaging as they flow through conveyor belts and cleats.

**TPS 300-HIZLI PAKETLEME MAKİNASI**  
 TPS 300- IN-LINE SPEED PACKAGING MACHINE  
 TPS 300 - MACHINE D'EMBALLAGE RAPIDE EN LIGNE  
 БЫСТРАЯ УПАКОВОЧНАЯ МАШИНА TPS 300  
 ماكينة تعبئة سريع TPS 300

technostar

**TPS 300**



**TEKNİK ÖZELLİKLER / TECHNICAL FEATURES**

VOLTAJ VOLTAGE	380 V + N + PE
GÜÇ POWER	14 KW
BOBİN GRUBU BOBBINE GROUP	OTOMATİK / AUTOMATIC
ÜRÜN TAŞIMA SENKRONU PRODUCT TRANSPORT SYNCHRON	OTOMATİK / AUTOMATIC
ÇENE BEKLEME AYARI JAW WAITING ADJUSTMENT	OTOMATİK / AUTOMATIC
FOTSEL AYARI PHOTOCELL ADJUSTMENT	OTOMATİK / AUTOMATIC
FREKANS FREQUENCY	50-60 Hz
ŞASE CHASSIS	304 CrNi
SERVO MOTOR SAYISI NUMBER OF SERVO MOTOR	8
AC MOTOR SAYISI NUMBER OF AC MOTOR	1
ÇENE GRUBU JAW GROUP	HIZLI ÇENE ÖZEL İMALAT SPEED JAW SPECIAL MANUFACTURING
DISK GRUBU DISC GROUP	3 ADET / 3 PCS
KAPASİTE CAPACITY	250-300 PAKET / DK 250-300 PACK / MIN
YAPIŞTIRMA ÖZELLİĞİ ADHESIVE FEATURE	SICAK / HOT
BESLEME TİPİ FEEDING TYPE	IN-LINE

**ÜRÜN ÖZELLİKLERİ**

E-motion kontrollü paketleme makinamız çikolata, gofret, kek vb. hatlardan gelen hassasiyeti önemli ürünlerinizin sıralama yöntemi ile yüksek devirlerde paketleme yapma özelliğine sahiptir. Diğer makinalara nazaran az enerji tüketimi kolay kullanım ve hijyenik bir ortamda üretim yapmanızı sağlar.

**PRODUCT FEATURES**

Our E-motion controlled packaging machine can be used for chocolate, wafer, cake etc. It has the feature of packing at high cycles with the sorting method of your sensitive products coming from the lines. Compared to other machines, it provides less energy consumption, easy use and production in a hygienic environment.



**TP ON EDGE**  
 Machine With Automatic Feeding System

technostar

**TP ON EDGE MACHINE-OTOMATİK BESLEMELİ BİSKÜVİ PAKETLEME MAKİNASI**  
 TP PACKAGING MACHINE FOR BISCUIT ON EDGE WITH AUTOMATIC FEEDING SYSTEM  
 TP MACHINE D'EMBALLAGE DE BISCUITS EN VERTICAL (ON EDGE) AVEC SYSTEME D'ALIMENTATION AUTOMATIQUE  
 TP ON EDGE MACHINE-УПАКОВОЧНАЯ МАШИНА ДЛЯ ПЕЧЕНЬ С АВТОМАТИЧЕСКОЙ ПОДАЧЕЙ  
 ماكينة تعبئة بسكويت التغذية الأوتوماتيكية TP ON EDGE MACHINE



**ÜRÜN ÖZELLİKLERİ**

Kremalı bisküviler için komple entegre kremalama ve paketleme hattıdır. Otomasyon besleme sistemi ile daha az iş gücü gereksinimi, daha az maliyet, daha yüksek karlılık imkânı sunulmaktadır.

**PRODUCT FEATURES**

It is a complete integrated creaming and packaging line for cream biscuits. With the automation feeding system, less labor requirement, less cost and higher profitability are offered.

**TEKNİK VERİLER**

- İstifleme sistemi bulunmaktadır.
- Gruplama ve bisküvi dizici sistemi mevcuttur.

**TECHNICAL DATA**

- There is a stacking system.
- Grouping and biscuit align system is available.

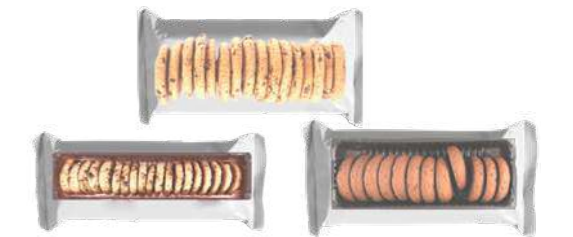

**TPF 200-YATAY PAKETLEME MAKİNASI**  
 TPF 200-HORIZONTAL PACKAGING MACHINE  
 TPF 200-MACHINE D'EMBALLAGE HORIZONTALE  
 ГОРИЗОНТАЛЬНАЯ УПАКОВОЧНАЯ МАШИНА  
 TPF 200-ماكينة تعبئة الأفقية

technostar

**TPF 200**



**TEKNİK ÖZELLİKLER / TECHNICAL FEATURES**

TOPLAM KURULU GÜÇ TOTAL INSTALLED POWER	6 KW
BESLEME GERİLİMİ SUPPLY VOLTAGE	380 V
ÇEKİLEN AKIM CURRENT CONSUMED	16 A
DİSK ISITICI GÜCÜ DISC HEATER POWER	2 x 600 W
ÇENE ISITICI GÜCÜ JAW HEATER POWER	2 x 600W
MOTOR GÜCÜ MOTOR POWER	2 x 1,1 KW
MOTOR GERİLİMİ MOTOR VOLTAGE	3 Faz 220 V / 3 Phases 220 V
KUMANDA DEVRESİ CONTROL CIRCUIT	24 V DC
ISITICILARA ELETRİK İLETİMİ ELECTRICAL CONDUCTION TO HEATERS	Kollektör, Fırça ve Kömür ile With Collector, Brush and Charcoal

**ÜRÜN ÖZELLİKLERİ**

Tekli, blok tip ya da kap içerisinde olan ürünlerin paketleme işlemlerini gerçekleştirmek için tasarlanmıştır. Paketleme işlemi hızlı ve seri şekilde gerçekleşmektedir.

**PRODUCT FEATURES**

It is designed to carry out the packaging operations of single, block type or products in a tray. The packaging process is carried out quickly and serially.



**TPF230 ROLL EKMEK PAKETLEME MAKİNASI**  
 TPF 230 ROLL BREAD PACKAGING MACHINE  
 TPF 230 MACHINE D'EMBALLAGE DE PETIT PAIN ROND  
 УПАКОВОЧНАЯ МАШИНА ФОРМОВОГО ХЛЕБА TPF230  
 TPF 230-ماكينة التعبئة خبز الرول

technostar

**TPF 230-PVC BANTLI YATAY PAKETLEME MAKİNASI**  
 TPF 230-HORIZONTAL FLOWPACK PACKAGING MACHINE WITH  
 PVC BAND FEEDING  
 PF 230-MACHINE D'EMBALLAGE HORIZONTALE AVEC BANDE PVC  
 ГОРИЗОНТАЛЬНАЯ УПАКОВОЧНАЯ МАШИНА С ПВХ ЛЕНТОЙ  
 TPF 230-ماكينة تعبئة الأفقية بحزام بي وي سي

**TPF 230-TBS**

**TPF 230**



**TEKNİK ÖZELLİKLER / TECHNICAL FEATURES**

TOPLAM KURULU GÜÇ TOTAL INSTALLED POWER	6 KW
BESLEME GERİLİMİ SUPPLY VOLTAGE	380 V
ÇEKİLEN AKIM CURRENT CONSUMED	16 A
DİSK ISITICI GÜCÜ DISC HEATER POWER	2 x 600 W
ÇENE ISITICI GÜCÜ JAW HEATER POWER	2 x 600W
MOTOR GÜCÜ MOTOR POWER	2 x 1,1 KW
MOTOR GERİLİMİ MOTOR VOLTAGE	3 Faz 220V / 3 Phases 220 V
KUMANDA DEVRESİ CONTROL CIRCUIT	24 V DC
ISITICILARA ELETRİK İLETİMİ ELECTRICAL CONDUCTION TO HEATERS	Kollektör, Fırça ve Kömür ile With Collector, Brush and Charcoal

**ÜRÜN ÖZELLİKLERİ**

Roll ekme, sandviç, hamburger gibi unlu mamullerin yanı sıra protein bar, çikolata bar, tablet nuga bar gibi ürünlerin de paketleme işlemini gerçekleştirmek için tasarlanmıştır. Müşteri isteğine göre besleme ünitesi tavalı, döner tepsili veya sadece transport beslemeli olarak dizayn edilebilmektedir. Çıkış bandının sağ ve sol tarafında bulunan torbalama sistemi sayesinde ve sayıcı yardımıyla istenen adette ürünün torbalara dolumu gerçekleşmektedir.

**PRODUCT FEATURES**

It is designed to carry out the packaging process of products such as protein bars, tablet or chocolate bars, nougat bars, as well as bakery products such as roll bread, sandwiches, hamburgers. According to the customer's request, the feeding unit can be designed with a pan, a rotating tray or only with a transport feed. Thanks to the bagging system on the right and left sides of the output band and with the help of the counter, the desired number of products are filled into the bags.



**TPF 240-MAGAZİNLİ YATAY FLOWPACK PAKETLEME MAKİNASI**  
 TPF 240- HORIZONTAL FLOWPACK PACKAGING MACHINE  
 WITH MAGAZINE FEEDING SYSTEM  
 MACHINE D'EMBALLAGE HORIZONTALE FLOWPACK AVEC MAGASIN  
 ГОРИЗОНТАЛЬНАЯ УПАКОВОЧНАЯ МАШИНА FLOWPACK С  
 МАГАЗИНОМ TPF 240  
 الأفقية بالمجلة Flowpack ماكينة تعبئة TPF 240

technostar

TPF 240



#### TEKNİK ÖZELLİKLER / TECHNICAL FEATURES

TOPLAM KURULU GÜÇ TOTAL INSTALLED POWER	6 KW
BESLEME GERİLİMİ SUPPLY VOLTAGE	380 V
ÇEKİLEN AKIM CURRENT CONSUMED	16 A
DİSK ISITICI GÜCÜ DISC HEATER POWER	2 x 600 W
ÇENE ISITICI GÜCÜ JAW HEATER POWER	2 x 600W
MOTOR GÜCÜ MOTOR POWER	2 x 1,1 KW
MOTOR GERİLİMİ MOTOR VOLTAGE	3 Faz 220V / 3 Phases 220 V
KUMANDA DEVRESİ CONTROL CIRCUIT	24 V DC

#### ÜRÜN ÖZELLİKLERİ

Magazin beslemeli tasarıma sahip olan makinamız bisküvi, kraker vb. düz ürünlerin beslemesini yapmaktadır. Ürün ölçüsüne ve paketlenme şekline göre magazin sistemi de değişebilmektedir.

#### PRODUCT FEATURES

Our machine, which has a magazine-feed system, can produce biscuits, crackers, etc. feeds flat products. Magazine system can also change according to product size and packaging.



TPF 250

technostar

**TPF 250-ALTAN SARMALI TERS YATAY PAKETLEME MAKİNASI**  
 TPF 250- BOTTOM WRAPPED REVERSE HORIZONTAL FLOWPACK  
 PACKING MACHINE  
 TPF 250-MACHINE D'EMBALLAGE HORIZONTALE AVEC PORTE BOBINE INVERSÉE  
 ОБРАТНАЯ ГОРИЗОНТАЛЬНАЯ УПАКОВОЧНАЯ МАШИНА С НИЖНЕЙ ОБЕРТКОЙ TPF 250  
 ماكينة التعبئة الأفقية العكسية أسفل التفاف TPF 250



#### TEKNİK ÖZELLİKLER / TECHNICAL FEATURES

TOPLAM KURULU GÜÇ TOTAL INSTALLED POWER	6 KW
BESLEME GERİLİMİ SUPPLY VOLTAGE	380 V
ÇEKİLEN AKIM CURRENT CONSUMED	16 A
DİSK ISITICI GÜCÜ DISC HEATER POWER	2 x 600 W
ÇENE ISITICI GÜCÜ JAW HEATER POWER	2 x 600W
MOTOR GÜCÜ MOTOR POWER	2 x 1,1 KW
MOTOR GERİLİMİ MOTOR VOLTAGE	3 Faz 220V / 3 Phases 220 V
KUMANDA DEVRESİ CONTROL CIRCUIT	24 V DC
ISITICILARA ELETRİK İLETİMİ ELECTRICAL CONDUCTION TO HEATERS	Kollektör, Fırça ve Kömür ile With Collector, Brush and Charcoal

#### ÜRÜN ÖZELLİKLERİ

Düzensiz şekilli olmayan ve çok taneli ürünleri alttan sararak paketlenmektedir. Meyve, sebze, balık vb. ürünlerin paketlenmesinde kullanılmak için tasarlanmıştır.

#### PRODUCT FEATURES

It packs irregularly shaped and multi-unit products by wrapping them from the bottom. Fruits, vegetables, fish, etc. It is designed to be used in the packaging of products.



**TPF 320-GEZER ÇENE PAKETLEME MAKİNASI**  
 TPF 320- FLOATING JAW PACKAGING MACHINE  
 TPF 320- MACHINE D'EMBALLAGE A MACHOIRE FLOTTANTE  
 УПАКОВОЧНАЯ МАШИНА С МОБИЛЬНОЙ ГОЛОВКОЙ TPF 320  
 ماكينة التعبئة فكية متنقلة TPF 320

technostar

**TPF 320**



### ÜRÜN ÖZELLİKLERİ

Farklı boyutlarda ürünlerin müşterinin istekleri dikkate alınarak besleme bandına aktaran ve e-motion kontrol ile paketlemesini sağlayarak uzun süre muhafaza edilmesine olanak sağlayan paketleme makinasıdır. Ürün ölçüleri standart olmayan tüm ürünlerin (kutu, sebze, meyve, tavuk vb.) paketlenmesi yapılabilmektedir.

### PRODUCT FEATURES

It is a packaging machine that transfers products of different sizes to the feeding belt, taking into account the customer's wishes, and allows them to be stored for a long time by packaging them with e-motion control. All products with non-standard product dimensions (box, vegetable, fruit, chicken, etc.) can be packaged.



**TPF 330**

technostar

**TPF 330-TERS GEZER ÇENE PAKETLEME MAKİNASI**  
 TPF 330- REVERSE BOBBIN FLOATING JAW PACKAGING MACHINE  
 TPF 330- MACHINE D'EMBALLAGE A MACHOIRE FLOTTANTE A BOBINE INVERSE  
 УПАКОВОЧНАЯ МАШИНА С ОБРАТНОЙ МОБИЛЬНОЙ ГОЛОВКОЙ TPF 330  
 ماكينة التعبئة فكية متنقلة العكسي TPF 330



### TEKNİK ÖZELLİKLER / TECHNICAL FEATURES

VOLTAJ VOLTAGE	380/200V
BOBİN GRUBU BOBBINE GROUP	MANUEL / MANUAL
ÜRÜN TAŞIMA SENKRONU PRODUCT TRANSPORT SYNCHRON	OTOMATİK / AUTOMATIC
FOTSEL AYARI PHOTOCELL ADJUSTMENT	OTOMATİK / AUTOMATIC
ŞASE CHASSIS	ST37+AISI304
OPERATÖR EKРАН OPERATOR SCREEN	RENKLİ DOKUNMATİK 7" COLOR TOUCH SCREEN 7"
YAPİŞTIRMA ÖZELLİĞİ ADHESIVE FEATURE	SICAK / HOT
BESLEME TİPİ FEEDING TYPE	MANUEL / MANUAL
KAPASİTE CAPACITY	80
TOPLAM KURULU GÜÇ TOTAL INSTALLED POWER	7 kW
SERVO SAYISI NUMBER OF SERVO MOTOR	5
PNÖMATİK PNEUMATIC	FESTO
KONTROL SİSTEMİ CONTROL SYSTEM	MONTION KONTROL MOTION CONTROL

### ÜRÜN ÖZELLİKLERİ

Farklı boyutlarda ürünleri müşterinin istekleri dikkate alınarak besleme bandına aktaran ve e-motion kontrol ile paketlemesini sağlayarak uzun süre muhafaza edilmesine olanak sağlayan paketleme makinasıdır. Ürünler konveyör bantlar vasıtasıyla paketlemeden sonra hazır hale getirilir. Ters gezer çene paketleme makinası ile ürün ölçüleri standart olmayan ve düzensiz olan tüm ürünlerin (kutu, sebze, meyve, tavuk vb.) paketlenmesi yapılabilmektedir.

### PRODUCT FEATURES

It is a packaging machine that transfers products of different sizes to the feeding belt, taking into account the wishes of the customer, and enables them to be stored for a long time by packaging them with e-motion control. The products are made ready after packaging by means of conveyor belts. With the reverse mobile jaw packaging machine, all products (box, vegetable, fruit, chicken, etc.) with non-standard and irregular product dimensions can be packaged.





**TPX 30-ZARF TİPİ KUTU PAKETLEME MAKİNASI**  
 TPX 30- X FOLD TYPE BOX PACKAGING MACHINE  
 TPX30- MACHINE D'EMBALLAGE POUR BOITES DE TYPE PLIEUSE EN X  
 УПАКОВОЧНЫЕ МАШИНЫ ДЛЯ КОРОБОК КОНВЕРТНОГО ТИПА TPX30  
 ماكينة التعبئة من النوع المغلف الصندوق TPX 30

technostar

TPX 30



### ÜRÜN ÖZELLİKLERİ

Makina tekli ve çoklu kutu paketlemesine uygun olarak tasarlanmıştır. Gıda, kimya, tütün, temizlik, kozmetik vb. sektörlerde geniş bir alanda tercih edilen üstten sarıp alından yapıştırarak zarf tipi paketlemeyi gerçekleştiren ideal kutu paketleme makinasıdır. Kolay açma bandı ve tarih basma ünitesi müşteri talebine göre opsiyoneldir.

### PRODUCT FEATURES

The machine is designed for single and multi-box packaging. Food, chemistry, tobacco, cleaning, cosmetics etc. It is the ideal box packaging machine that performs envelope type (X Fold) packaging by wrapping from the top and pasting from the forehead, which is preferred in a wide area in the sectors. Easy opening tape and date printing unit are optional according to customer demand.

TPX 50

technostar

**TPX 50-ZARF TİPİ PAKETLEME MAKİNASI**  
 TPX 50- X FOLD TYPE PACKAGING MACHINE  
 TPX 50- MACHINE D'EMBALLAGE DE TYPE PLIEUSE EN X  
 УПАКОВОЧНЫЕ МАШИНЫ КОНВЕРТНОГО ТИПА TPX 350  
 ماكينة التعبئة من النوع المغلف TPX 50

### TEKNİK ÖZELLİKLER / TECHNICAL FEATURES

BOBİN GRUBU BOBBINE GROUP	MANUEL / MANUAL
ÜRÜN TAŞIMA SENKRONU PRODUCT TRANSPORT SYNCHRON	OTOMATİK / AUTOMATIC
FOTOSEL AYARI PHOTOCELL ADJUSTMENT	OTOMATİK / AUTOMATIC
ŞASE CHASSIS	ST37+AISI304
OPERATÖR EKРАН OPERATOR SCREEN	RENKLİ DOKUNMATİK 5.7" COLOR TOUCH SCREEN 5.7"
YAPIŞTIRMA ÖZELLİĞİ ADHESIVE FEATURE	SICAK / HOT
BESLEME TİPİ FEEDING TYPE	MANUEL / MANUAL
BESLEME GERİLİMİ SUPPLY VOLTAGE	380V
KAPASİTE CAPACITY	30-50 PACK / MIN
TOPLAM KURULU GÜÇ TOTAL INSTALLED POWER	3,5 kW
ASENKRON MOTOR SAYISI NUMBER OF AC MOTOR	1
SERVO SAYISI NUMBER OF SERVO MOTOR	1
PNÖMATİK PNEUMATIC	FESTO
BOYUNA ISITICI GÜCÜ LONGITUDINAL HEATER POWER	400 W (220 volt)
ALIN ISITICI GÜCÜ SIDE HEATER POWER	3 x 200W (220 volt)
MOTOR GÜCÜ MOTOR POWER	1,1 kW
MOTOR GERİLİMİ MOTOR VOLTAGE	3 Faz 220V / 3 Phases 220V
KUMANDA DEVRESİ CONTROL CIRCUIT	24V DC 3A Sigorta Korumalı 24V DC 3A Fuse-Protected
KUMANDA BESLEME CONTROL FEED	220V,24V DC



### ÜRÜN ÖZELLİKLERİ

Farklı boyutlarda ürünlerin müşterinin istekleri dikkate alınarak transport yardımıyla üstten sarma ve alından yapıştırma ile paketlemesini sağlayarak uzun süre muhafaza edilmesine olanak sağlayan paketleme makinasıdır. Makina tekli ve çoklu ürün paketlemesine uygun olarak tasarlanmıştır. Kolay açma bandı ve tarih basma ünitesi opsiyonel olarak ilave edilebilir.

### PRODUCT FEATURES

It is a packaging machine that allows the products of different sizes to be stored for a long time by packaging them with the help of transport, by wrapping from the top and sealing from the forehead, taking into account the wishes of the customer. The machine is designed for single and multiple product packaging. Easy opening tape and date printing unit can be added optionally.

### PAKETLEYEBİLECEĞİ ÜRÜN ÖLÇÜLERİ PRODUCT DIMENSIONS THAT IT CAN PACK

BOYUT / DIMENSION	MİN-MAX ARALIĞI(mm) MIN.-MAX. RANGE (mm)
Boy / Length	50-280
Genişlik / Width	25-140
Yükseklik / Height	15-90

**TPF 150-YAN BESLEMELİ BİSKÜVİ PAKETLEME MAKİNASI**  
 TPF 150- SIDE FEEDING BISCUIT PACKAGING MACHINE  
 TPF150- MACHINE D'EMBALLAGE POUR BISCUITS A  
 ALIMENTATION LATÉRALE  
 УПАКОВОЧНАЯ МАШИНА ДЛЯ ПЕЧЕНЬЯ С БОКОВОЙ ПОДАЧЕЙ TPF150  
 ماكينة التعبئة بتغذية البسكويت الجانبية TPF150

technostar

## TPF 150 On Edge Machine



### ÜRÜN ÖZELLİKLERİ

Bisküvi, kraker vb. ürünleri çoklu olarak kulaklı tip paketleme yapar. Ürünler 90° bant üzerinde bulunan miller arasında manuel şekilde elle dizilir. Ürünlerin miller arasındaki hareketinin başlamasıyla askerler arasında aktararak paketlemesi sağlanır. Müşteri isteğine bağlı olarak üretim hattı, bisküvi kremalama makinası ve bisküvi paketleme makinası senkronize edilerek el değmeden otomatik besleme ve e-motion kontrol sistemi sayesinde yüksek kapasitelerde paketleme yapılabilir.

### PRODUCT FEATURES

It makes multi-ear type packaging products like biscuits, crackers, etc.. The products are manually stacked between the spindle on the 90° belt. With the start of the movement of the products between the spindle, they are transferred between the cleats and packaged. Depending on the customer's request, the production line, biscuit creaming machine and biscuit packaging machine can be synchronized, and high-capacity packaging can be made thanks to the automatic feeding and e-motion control system without human touch.

### TEKNİK VERİLER

- PID ısı kontrol sistemi bulunmaktadır.
- Tarih basma ünitesi, çift bobin ve körüklü paket yapma aparatı opsiyonel olarak bulunmaktadır.
- Fotoselli ve fotoselsiz çalışabilmektedir.
- PLC elektronik kontrol sistemi bulunmaktadır.

### TECHNICAL DATA

- There is a PID temperature control system.
- Date printing unit, double coil and bellows package making apparatus are optionally available.
- It can work with or without photocell.
- There is a PLC electronic control system.



## TPSM 1000

technostar

**TPSM 1000-BİSKÜVİ KREMLAMA MAKİNASI**  
 TPSM 1000- BISCUIT CREAMING & SANDWICHING MACHINE  
 TPSM 1000- MACHINE CREMEUSE ET SANDWICHEUSE POUR BISCUITS  
 МАШИНЫ ДЛЯ ПЕЧЕНЬЯ С НАЧИНКОЙ TPSM 1000  
 ماكينة كريمه البسكويت TPSM 1000

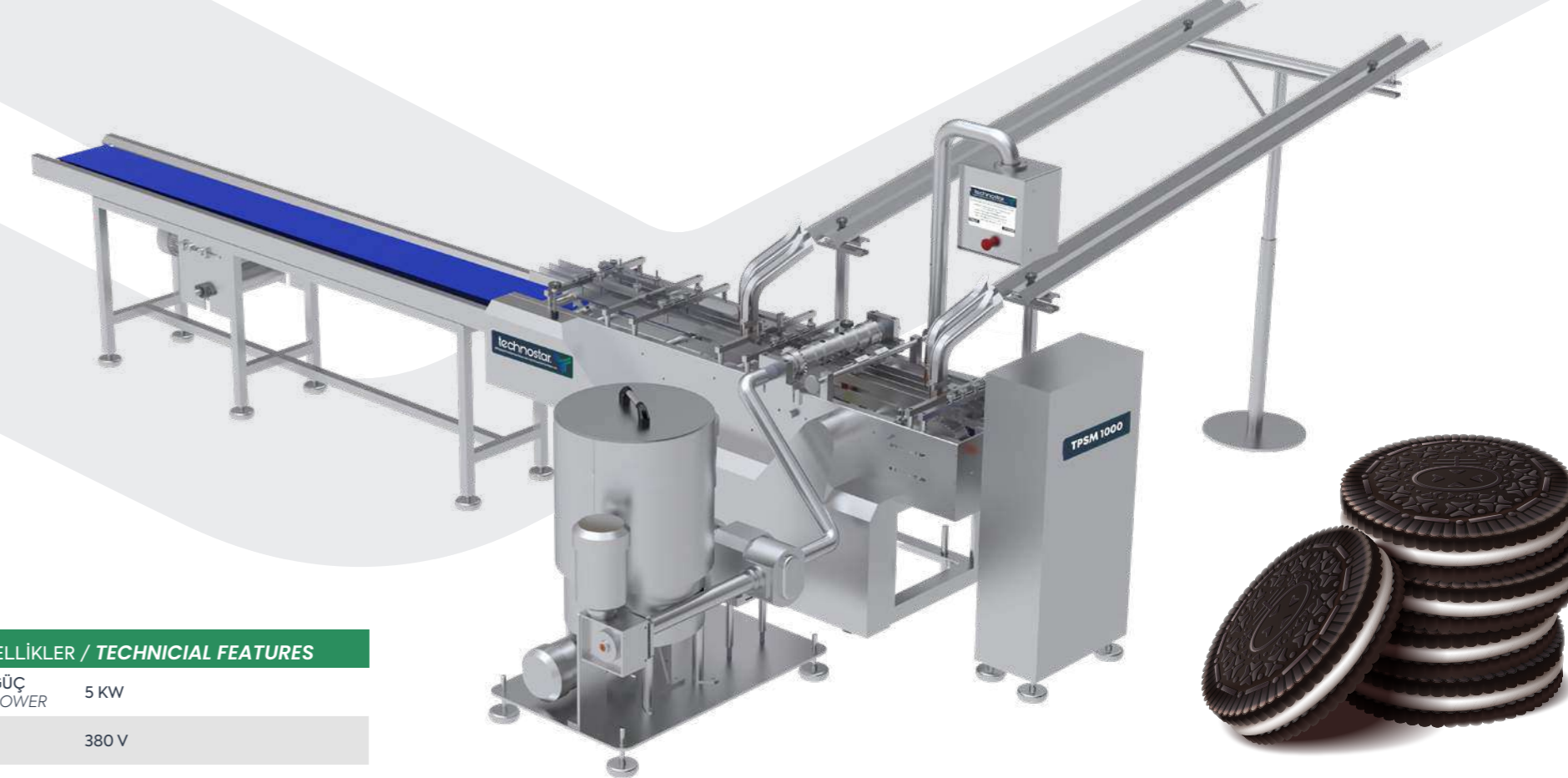

### TEKNİK ÖZELLİKLER / TECHNICAL FEATURES

TOPLAM KURULU GÜÇ TOTAL INSTALLED POWER	5 kW
BESLEME GERİLİMİ SUPPLY VOLTAGE	380 V
ÇEKİLEN AKIM CURRENT CONSUMED	13 A
MOTOR GERİLİMİ MOTOR VOLTAGE	3 Faz 220V / 3 Phases 220 V
ANMA GÜCÜ RATED POWER	10 kW
KUMANDA DEVRESİ CONTROL CIRCUIT	24 V DC
MOTOR GÜCÜ MOTOR POWER	1x 2,2 kW - 1x 1,5 kW - 1x 0,75 kW

### ÜRÜN ÖZELLİKLERİ

Değişik ebatlarda dairesel ve köşeli bisküvilerin dengeli ve istenen miktarda kremalanmasına olanak sağlayan ve düzgün biçimde taşıma bandına aktaran mekanizmaların bütünüdür. Kremalama makinasımız, 1 manifold ve 2 kanaldan oluşmaktadır.

### PRODUCT FEATURES

It is the whole of the mechanisms that allow circular and angular biscuits of different sizes to be creamed in a balanced and desired amount and smoothly transferred to the conveyor belt. Our creaming machine consists of 1 manifolds and 2 channels.

**TPSM 2000-BİSKÜVİ KREMALAMA MAKİNASI**  
TPSM 2000- BISCUIT CREAMING & SANDWICHING MACHINE  
TPSM 2000- MACHINE CREMEUSE ET SANDWICHEUSE POUR BISCUITS  
МАШИНЫ ДЛЯ ПЕЧЕНЬЯ С НАЧИНКОЙ TPM 2000  
ماكينه كريمه البسكويت TPM 2000

technostar

## TPSM 2000



### TEKNİK ÖZELLİKLER / TECHNICAL FEATURES

TOPLAM KURULU GÜÇ TOTAL INSTALLED POWER	6.6 kW
BESLEME GERİLİMİ SUPPLY VOLTAGE	380 V
ÇEKİLEN AKIM CURRENT CONSUMED	13 A
MOTOR GÜCÜ MOTOR POWER	3x2.2 kW- 2x1.1 kW- 2x0.75 kW
MOTOR GERİLİMİ MOTOR VOLTAGE	3 Faz 220V / 3 Phases 220 V
KUMANDA DEVRESİ CONTROL CIRCUIT	24 V DC
KAPASİTE CAPACITY	2000 Devir / dk. / 2000 RPM

### ÜRÜN ÖZELLİKLERİ

Değişik ebatlarda dairesel ve köşeli bisküvilerin dengeli ve istenen miktarda kremalanmasına olanak sağlayan ve düzgün biçimde taşıma bandına aktaran mekanizmaların bütünüdür. Kremalama makinamız, 2 manifold ve 4 kanaldan oluşmaktadır. Çift renk opsiyonu müşteri talebi doğrultusunda eklenebilir.

### PRODUCT FEATURES

It is the whole of the mechanisms that allow circular and angular biscuits of different sizes to be creamed in a balanced and desired amount and smoothly transferred to the conveyor belt. Our creaming machine consists of 2 manifolds and 4 channels. Double color in a sandwich is an optional according customer request.

## TPSM 3000

technostar

**TPSM 3000-BİSKÜVİ KREMALAMA MAKİNASI**  
TPSM 3000- BISCUIT CREAMING & SANDWICHING MACHINE  
TPSM 3000- MACHINE CREMEUSE ET SANDWICHEUSE POUR BISCUITS  
МАШИНЫ ДЛЯ ПЕЧЕНЬЯ С НАЧИНКОЙ TPM 3000  
ماكينه كريمه البسكويت TPM 3000



### TEKNİK ÖZELLİKLER / TECHNICAL FEATURES

TOPLAM KURULU GÜÇ TOTAL INSTALLED POWER	27.4 kW
BESLEME GERİLİMİ SUPPLY VOLTAGE	380 V
ÇEKİLEN AKIM CURRENT CONSUMED	13 A
MOTOR GÜCÜ MOTOR POWER	1x3 kW- 6x2.2 kW- 4x0.55 kW-12x0.75 kW
MOTOR GERİLİMİ MOTOR VOLTAGE	3 Faz 220V / 3 Phases 220 V
KUMANDA DEVRESİ CONTROL CIRCUIT	24 V DC
KAPASİTE CAPACITY	1800 Ürün / dk. / 1800 product / min.

### ÜRÜN ÖZELLİKLERİ

Değişik ebatlarda dairesel ve köşeli bisküvilerin dengeli ve istenen miktarda kremalanmasına olanak sağlayan ve düzgün biçimde taşıma bandına aktaran mekanizmaların bütünüdür. Kremalama makinamız, 3 manifold ve 6 kanaldan oluşmaktadır. Çift renk opsiyonu müşteri talebi doğrultusunda eklenebilir.

### PRODUCT FEATURES

It is the whole of the mechanisms that allow circular and angular biscuits of different sizes to be creamed in a balanced and desired amount and smoothly transferred to the conveyor belt. Our creaming machine consists of 3 manifolds and 6 channels. Double color in a sandwich is an optional according customer request.

**PSM 250-PUDRA ŞEKERİ DEĞİRMENİ**  
PSM 250- POWDER SUGAR MILL  
PSM 250- MOULIN A SUCRE EN POUDRE  
МЕЛЬНИЦА ДЛЯ САХАРНОЙ ПУДРЫ PSM 250  
مطحنة السكر PSM 250 بودة

technostar

## PSM 250



### ÜRÜN ÖZELLİKLERİ

Pudra şekeri değirmeni; gofret ve çikolata da kullanılmak üzere şekeri inceltip pudra haline getiren bir makinadır. Vakum emmeli, elekli ve helazonik aktarmalıdır. 30-35 mikron incelikte pudra şekeri elde edilir. Şekeri koyacak iç haznesi tamamen CrNi paslanmaz malzemeden üretilmektedir.

### PRODUCT FEATURES

Powdered sugar mill; It is a machine that refines and turns sugar into powder for use in wafers and chocolate. Vacuum suction, sieve and spiral transfer. 30-35 micron fine powdered sugar is obtained. The inner chamber to put the sugar is produced entirely from CrNi stainless material.

### TEKNİK VERİLER

- 4 kw gücünde ana motor ve 0.75 kw gücünde helazon redüktörü kullanılmıştır.
- Helazonun üzerinde iki adet toz tutucu filtre vardır.

### TECHNICAL DATA

- 4 kW main motor and 0.75 kW spiral reducer are used.
- There are two dust holding filters on the auger.

**PSM 500-PUDRA ŞEKERİ DEĞİRMENİ**  
PSM 500- POWDER SUGAR MILL  
PSM 500- MOULIN A SUCRE EN POUDRE  
МЕЛЬНИЦА ДЛЯ САХАРНОЙ ПУДРЫ PSM 500  
مطحنة السكر PSM 500 بودة

## PSM 500



### ÜRÜN ÖZELLİKLERİ

Pudra şekeri değirmeni, kristal şekeri öğütürerek toz şekeri yapmak için tasarlanmıştır. Şeker dövme haznesi AISI 304 paslanmaz çelikten imal edilir ve üzerinde elek sistemi vardır. 30-140 mikron arası incelikte pudra şekeri elde edilir.

### TEKNİK VERİLER

- Öğütme motor gücü 11 kw ve kayış kasnak sistemine sahiptir.
- Helazon motor güçleri 1,1 ve 0,75 kW' tır.
- Çalışma voltajı 380V, toplam kurulu gücü 13 kW' tır.

### PRODUCT FEATURES

The powdered sugar mill is designed to grind crystal sugar to make granulated sugar. Sugar forging chamber is made of AISI 304 stainless steel and has a sieve system on it. Powdered sugar of 30-140 microns is obtained.

### TECHNICAL DATA

- Grinding motor power of 11 kW and a belt and pulley system.
- Spiral motor powers are 1.1 and 0.75 kW.
- Working voltage is 380V, total installed power is 13 kW.

technostar

**BESLEME SİSTEMLERİ**  
FEEDING SYSTEM  
SYSTEMES D'ALIMENTATION  
СИСТЕМЫ АВТОМАТИЧЕСКОЙ ПОДАЧИ ПРОДУКТА  
أنظمة التغذية

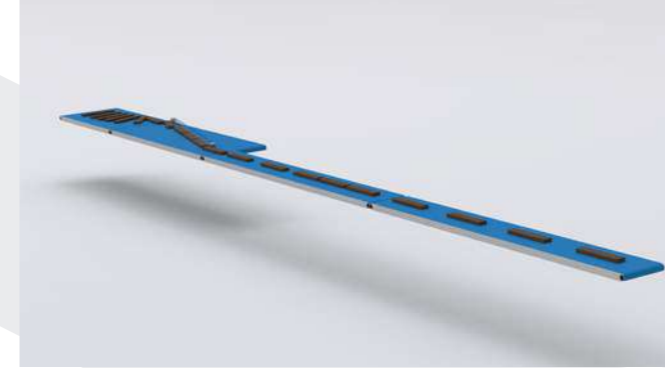

İnline Besleme Sistemi  
In-Line Feeding System

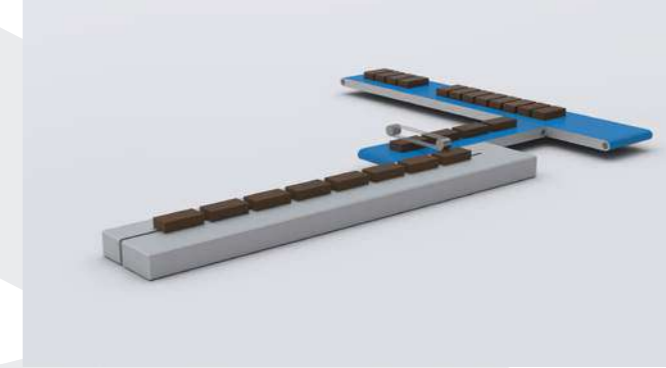

Blok Besleme Sistemi  
Block Feeding System

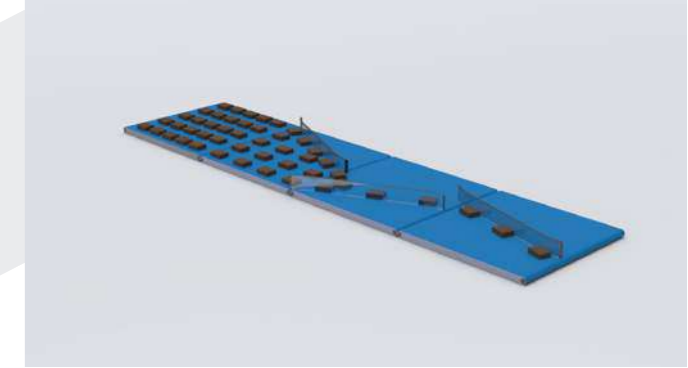

Sıralayıcı Besleme Sistemi  
Feeding System Sequencer

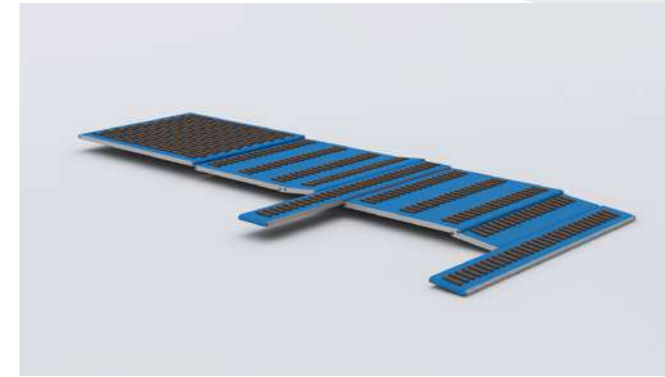

İki Makinalı Bar Dağıtım Sistemi  
Double Machine Bar Distribution System

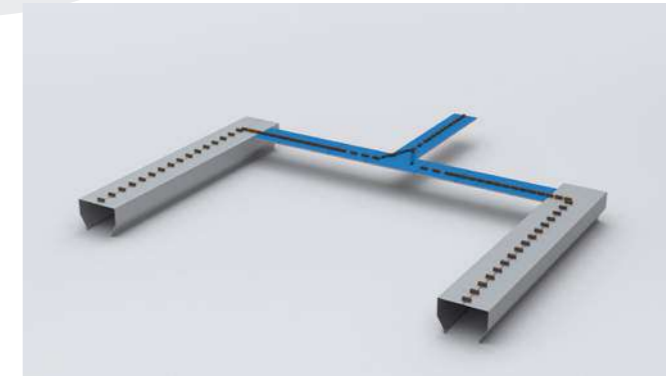

Çift Makina Besleme Sistemi  
Double Machine Feeding System

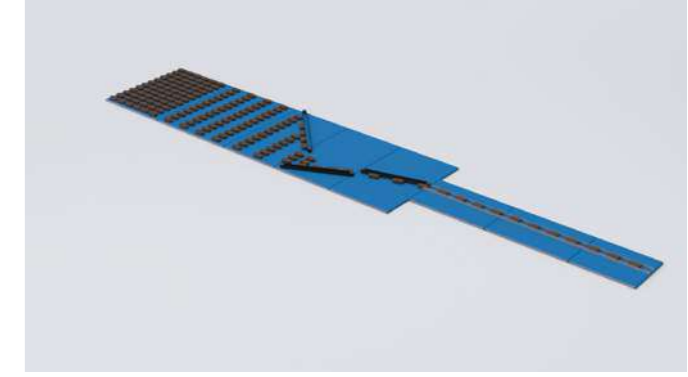

İnline Besleme Sistemi  
In-Line Feeding System

**TAM OTOMATİK 14 TERAZİLİ PAKETLEME MAKİNASI**  
**FULL AUTOMATIC 14 SCALE PACKAGING MACHINE**  
**MACHINE D'EMBALLAGE AUTOMATIQUE A 14 BALANCES**  
**ПОЛНОСТЬЮ АВТОМАТИЧЕСКАЯ УПАКОВОЧНАЯ МАШИНА С 14 ВЕСАМИ**  
 ماكينة التعبئة ذات 14 نطاق أوتوماتيكي بالكامل

technostar

## TPV-1000-MWP

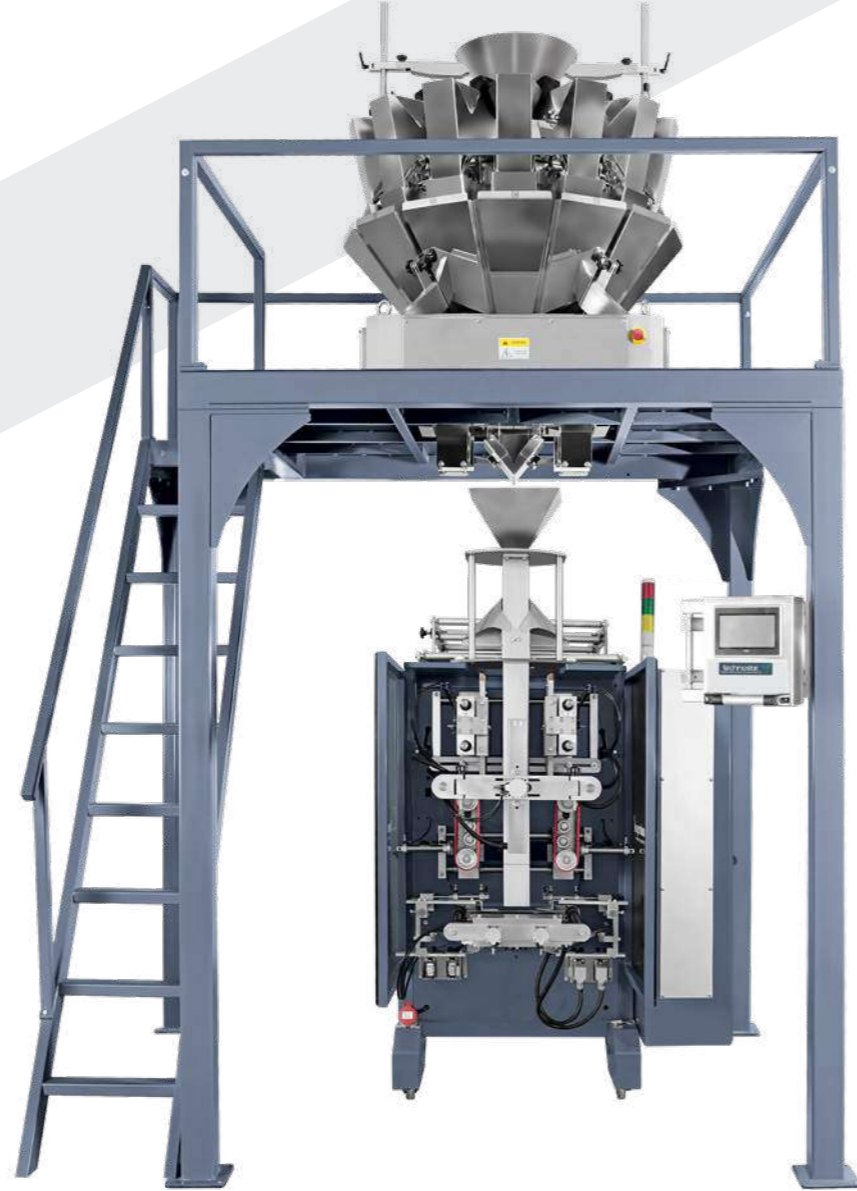

### TEKNİK ÖZELLİKLER / TECHNICAL FEATURES

<b>DOLUM SİSTEMİ</b> FILLING SYSTEM	10-14-18 Multihead Dolum Ünitesi 10-14-18 Multihead filling unit
<b>PAKETLENEN ÜRÜNLER</b>	Kuruyemiş, bakliyat, makarna, şekerleme, toz şeker, bisküvi, gofret, dondurulmuş ürünler, kurutulmuş meyve gibi taneli ürünler
<b>PACKED PRODUCTS</b>	Grain products such as nuts, pulses, pasta, confectionery, granulated sugar, biscuits, wafers, frozen products, dried fruit
<b>KAPASİTE</b>	30-75 pk/dk (ürüne, paket tipine, ambalaja ve gramaja göre değişiklik gösterebilir.) Not: bu kapasite 14 kefli dolum ünitesi için geçerlidir.
<b>CAPACITY</b>	30-75 pack/min (may vary depending on product, package type, package and weight.) Note: this capacity is valid for 14 head filling unit.
<b>PAKET TİPLERİ</b> PACKAGE TYPES	Yastık, Körüklü, Quadro Paket Pillow, Gusseted, Quadro Package
<b>MAKİNA ÖLÇÜLERİ</b> (en x boy x yükseklik) MACHINE DIMENSIONS (width x length x height)	3000 x 2500 x 3560 mm (elevatör hariç) 3000 x 2500 x 3560 mm (except elevator)
<b>AĞIRLIK</b> WEIGHT	2500 kg
<b>ELEKTRİK İHTİYACI</b> ELECTRICITY NEED	3x380V/50Hz
<b>ELEKTRİK TÜKETİMİ</b> ELECTRICITY CONSUMPTION	10 kW (kompresör dâhil) 10 kW (including compressor)
<b>HAVA GEREKSİNİMİ</b> AIR REQUIREMENT	500 lt /6-8 bar
<b>KULLANILAN AMBALAJ</b> PACKAGING USED	OPP/CPP - PET/AL - ve diğer lamineli filmler OPP/CPP - PET/AL - and other laminated films



Yastık Paket  
Pillow Package



Körüklü Paket  
Stan Up Package



Quadro Paket \*  
Quadro Package



Quadro Paket \*\*  
Quadro Package



Punch Slot Aska Deliği  
Pillow Package



Euro Slot Aska Deliği  
Pillow Package



El Geçmeli Paket  
Hand Punch

\* 4 Kenar Yapıştırma  
4 Edge Banding  
\*\* 5 Kenar Yapıştırma  
5 Edge Banding

## TPV-1000-IWP

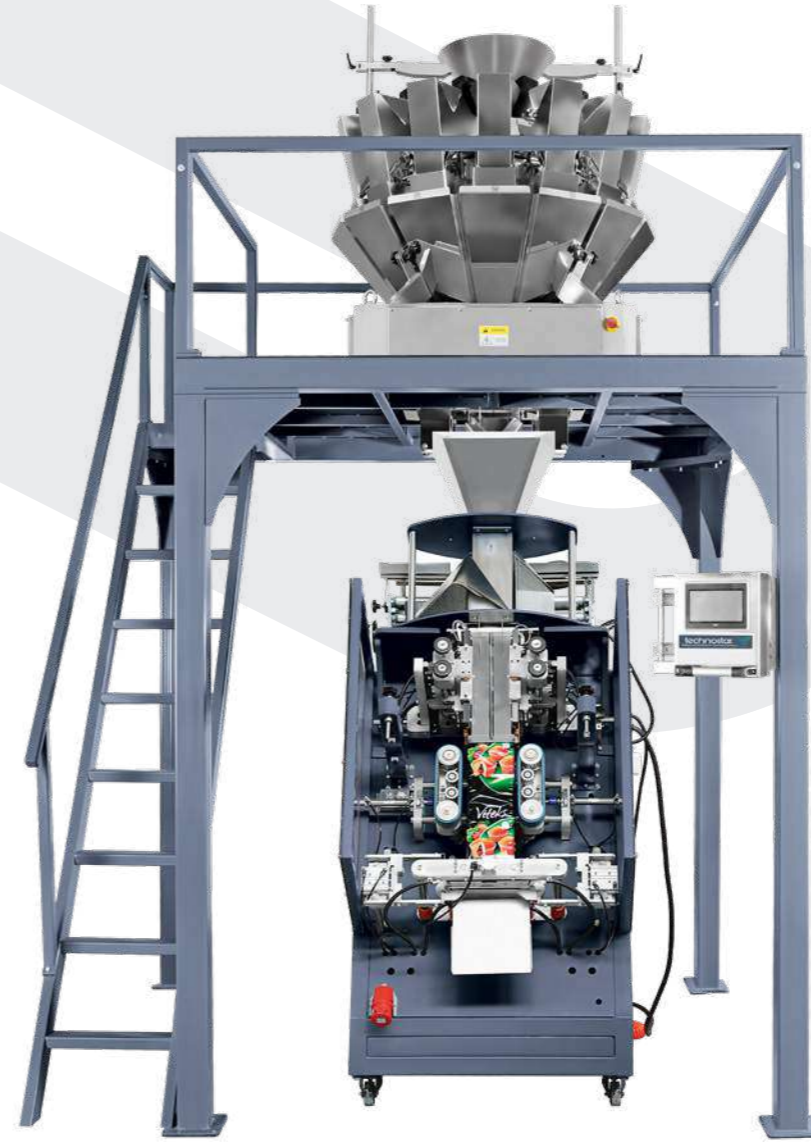

### TEKNİK ÖZELLİKLER / TECHNICAL FEATURES

<b>DOLUM SİSTEMİ</b> FILLING SYSTEM	10-14-18 Multihead dolum ünitesi / 2-4 kefli lineer dolum ünitesi 10-14-18 Multihead filling unit / 2-4 scales linear filling unit
<b>PAKETLENEN ÜRÜNLER</b>	Tane olarak büyük akma ve kırılma olasılığı olan tüm ürünler paketlenir. Top kek, küp kek, bisküvi vb.
<b>PACKED PRODUCTS</b>	All products that have the possibility of large leakage and breakage as grains are packaged. Cupcakes, cupcakes, biscuits, etc.
<b>KAPASİTE</b>	15-30 pk/dk (ürüne, paket tipine, ambalaja ve gramaja göre değişiklik gösterebilir.) Not: Bu kapasite 14 kefli dolum ünitesi için geçerlidir.
<b>CAPACITY</b>	15-30 pack/min (may vary depending on product, package type, package and weight.) Note: This capacity is valid for 14 scales filling units.
<b>PAKET TİPLERİ</b> PACKAGE TYPES	Yastık, Körüklü, Quadro Paket Pillow, Gusseted, Quadro Package
<b>MAKİNA ÖLÇÜLERİ</b> (en x boy x yükseklik) MACHINE DIMENSIONS (width x length x height)	2600 x 2000 x 3550 mm (elevatör hariç) 2600 x 2000 x 3550 mm (except elevator)
<b>AĞIRLIK</b> WEIGHT	1750 kg
<b>ELEKTRİK İHTİYACI</b> ELECTRICITY NEED	3x380V/50Hz
<b>ELEKTRİK TÜKETİMİ</b> ELECTRICITY CONSUMPTION	10 kW (kompresör dâhil) 10 kW (including compressor)
<b>HAVA GEREKSİNİMİ</b> AIR REQUIREMENT	500 lt /6-8 bar
<b>KULLANILAN AMBALAJ</b> PACKAGING USED	OPP/CPP - PET/AL - ve diğer lamineli filmler OPP/CPP - PET/AL - and other laminated films



Yastık Paket  
Pillow Package



Körüklü Paket  
Stan Up Package



Quadro Paket \*  
Quadro Package



Quadro Paket \*\*  
Quadro Package



Punch Slot Aska Deliği  
Pillow Package



Euro Slot Aska Deliği  
Pillow Package



El Geçmeli Paket  
Hand Punch

\* 4 Kenar Yapıştırma  
4 Edge Banding  
\*\* 5 Kenar Yapıştırma  
5 Edge Banding

**TAM OTOMATİK 4 TERAZİLİ PAKETLEME MAKİNASI**  
**FULL AUTOMATIC 4 SCALE PACKAGING MACHINE**  
**MACHINE D'EMBALLAGE AUTOMATIQUE A 4 BALANCES**  
**ПОЛНОСТЬЮ АВТОМАТИЧЕСКАЯ УПАКОВОЧНАЯ МАШИНА С 4 ВЕСАМИ**  
 Makine teçibe 4 matayis otomatikiye bakaal

technostar

## TPV4-5000-LWP

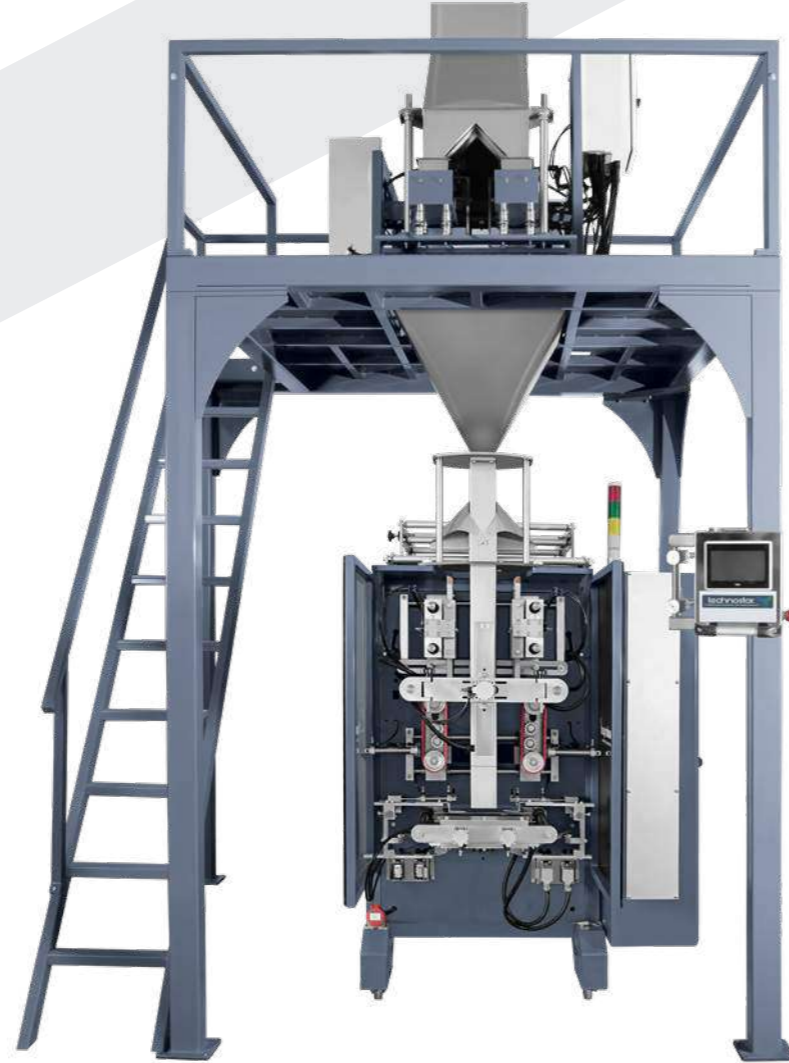

### TEKNİK ÖZELLİKLER / TECHNICAL FEATURES

<b>DOLUM SİSTEMİ</b> FILLING SYSTEM	4 terazili lineer dolum ünitesi Linear filling unit with 4 scales
<b>PAKETLENEN ÜRÜNLER</b> PACKED PRODUCTS	200 - 1000 gr Kuruyemiş (Önerilen Çok Kefeli Terazi) 500 - 5000 gr Bakliyat, Toz Şeker, Toz Deterjan 3000 - 10.000 gr Toz Deterjan / Kedi Kumu
<b>KAPASİTE</b> CAPACITY	200 - 1000 gr Nuts (Recommended Multihead Scale) 500 - 5000 gr Pulses, Powdered Sugar, Powdered Detergent 3000 - 10.000 gr Powder Detergent / Cat Litter 8-35 pk/dk (Ürüne, ambalaja ve gramaja göre değişiklik gösterebilir.) Not: Bu kapasite 14 kefeli dolum ünitesi için geçerlidir.
<b>PAKET TİPLERİ</b> PACKAGE TYPES	8-35 pack/min (May vary depending on product, packaging and weight.) Note: This capacity is valid for 4 pan filling unit.
<b>MAKİNA ÖLÇÜLERİ</b> (en x boy x yükseklik) MACHINE DIMENSIONS (width x length x height)	Yastık, Körüklü, Quadro Paket Pillow, Gusseted, Quadro Package
<b>AĞIRLIK</b> WEIGHT	3000 x 2500 x 3560 mm (elevatör hariç) 3000 x 2500 x 3560 mm (except elevator)
<b>ELEKTRİK İHTİYACI</b> ELECTRICITY NEED	2000 kg
<b>ELEKTRİK TÜKETİMİ</b> ELECTRICITY CONSUMPTION	3x380V/50Hz
<b>HAVA GEREKSİNİMİ</b> AIR REQUIREMENT	10 kW (kompresör dâhil) 10 kW (including compressor)
<b>KULLANILAN AMBALAJ</b> PACKAGING USED	500 lt /6-8 bar
	OPP/CPP - PET/AL - ve diğer lamineli filmler OPP/CPP - PET/AL - and other laminated films



Yastık Paket Pillow Package    Körüklü Paket Stan Up Package    Quadro Paket \* Quadro Package    Quadro Paket \*\* Quadro Package    Punch Slot Aska Deliği Pillow Package    Euro Slot Aska Deliği Pillow Package    El Geçmeli Paket Hand Punch

\* 4 Kenar Yapıştırma  
4 Edge Banding  
\*\* 5 Kenar Yapıştırma  
5 Edge Banding

## TPV2-5000-LWP

technostar

**TAM OTOMATİK 2 TERAZİLİ PAKETLEME MAKİNASI**  
**FULL AUTOMATIC 2 SCALE PACKAGING MACHINE**  
**MACHINE D'EMBALLAGE AUTOMATIQUE A 2 BALANCES**  
**ПОЛНОСТЬЮ АВТОМАТИЧЕСКАЯ УПАКОВОЧНАЯ МАШИНА С 2 ВЕСАМИ**  
 Makine teçibe otomatikiye bakaal 2 natıq



### TEKNİK ÖZELLİKLER / TECHNICAL FEATURES

<b>DOLUM SİSTEMİ</b> FILLING SYSTEM	2 terazili lineer dolum ünitesi Linear filling unit with 2 scales
<b>PAKETLENEN ÜRÜNLER</b> PACKED PRODUCTS	200 gr - 1000 gr Kuruyemiş (Önerilen multihead dolum ünitesi) 500 gr - 5000 gr Bakliyat - Toz Şeker / Toz Deterjan 3000 gr - 10000 gr Toz Deterjan / Kedi Kumu
<b>KAPASİTE</b> CAPACITY	200 gr - 1000 gr Nuts (recommended multihead filling unit) 500 gr - 5000 gr Pulses, Powdered Sugar, Powdered Detergent 3000 gr - 10000 gr Powder Detergent / Cat Litter 8-25 pk/dk (ürüne, paket tipine, ambalaja ve gramaja göre değişiklik gösterebilir.)
<b>PAKET TİPLERİ</b> PACKAGE TYPES	8-25 pack/min (may vary depending on product, package type, package and weight.)
<b>MAKİNA ÖLÇÜLERİ</b> (en x boy x yükseklik) MACHINE DIMENSIONS (width x length x height)	Yastık, Körüklü, Quadro Paket Pillow, Gusseted, Quadro Package
<b>AĞIRLIK</b> WEIGHT	2500 x 2000 x 3250 mm (elevatör hariç) 2600 x 2000 x 3550 mm (except elevator)
<b>ELEKTRİK İHTİYACI</b> ELECTRICITY NEED	1500 kg
<b>ELEKTRİK TÜKETİMİ</b> ELECTRICITY CONSUMPTION	3x380V/50Hz
<b>HAVA GEREKSİNİMİ</b> AIR REQUIREMENT	10 kW (kompresör dâhil) 10 kW (including compressor)
<b>KULLANILAN AMBALAJ</b> PACKAGING USED	500 lt /6-8 bar
	OPP/CPP - PET/AL - ve diğer lamineli filmler OPP/CPP - PET/AL - and other laminated films



Yastık Paket Pillow Package    Körüklü Paket Stan Up Package    Quadro Paket \* Quadro Package    Quadro Paket \*\* Quadro Package    Punch Slot Aska Deliği Pillow Package    Euro Slot Aska Deliği Pillow Package    El Geçmeli Paket Hand Punch

\* 4 Kenar Yapıştırma  
4 Edge Banding  
\*\* 5 Kenar Yapıştırma  
5 Edge Banding

**ÇİFT SİSTEM TAM OTOMATİK PAKETLEME MAKİNASI**  
 DOUBLE SYSTEM FULL AUTOMATIC PACKAGING MACHINE  
 MACHINE D'EMBALLAGE AUTOMATIQUE A DOUBLE SYSTEME  
 ПОЛНОСТЬЮ АВТОМАТИЧЕСКАЯ УПАКОВОЧНАЯ МАШИНА НА  
 ДВОЙНОЙ СИСТЕМЕ  
 ماكينة التعبئة أوتوماتيكية بنظام مزدوج

technostar

TPV-1000-WSP

TPV-1000-CPM

technostar

**KAROSELLİ PAKETLEME MAKİNASI**  
 CAROSEL PACKAGING MACHINE  
 MACHINE D'EMBALLAGE CAROSEL  
 КАРУСЕЛЬНАЯ УПАКОВОЧНАЯ МАШИНА  
 ماكينة التغليف كاروسيل

**TEKNİK ÖZELLİKLER / TECHNICAL FEATURES**

<b>DOLUM SİSTEMİ</b> FILLING SYSTEM	Vidalı ve terazili dolum ünitesi Screw and scale filling unit
<b>PAKETLENEN ÜRÜNLER</b>	20-1000 gr tozlu ve taneli ürün çeşitleri
<b>PACKED PRODUCTS</b>	20-1000 gr powdery and granular product types
<b>KAPASİTE</b>	Vidalı 25-70 pk/dk Terazili 18-30 pk/dk (Ürüne, ambalaja ve gramaja göre değişiklik gösterebilir.)
<b>CAPACITY</b>	Screw 25-70 pack/min Scale 18-30 pack/min (It may vary depending on the product, packaging and weight.)
<b>PAKET TİPLERİ</b> PACKAGE TYPES	Yastık, Körüklü, Quadro Paket Pillow, Gusseted, Quadro Package
<b>MAKİNA ÖLÇÜLERİ</b> (en x boy x yükseklik) MACHINE DIMENSIONS (width x length x height)	2500 x 3000 x 3460 mm (elevatör hariç) 2500 x 3000 x 3460 mm (except elevator)
<b>AĞIRLIK</b> WEIGHT	1800 kg
<b>ELEKTRİK İHTİYACI</b> ELECTRICITY NEED	3x380V/50Hz
<b>ELEKTRİK TÜKETİMİ</b> ELECTRICITY CONSUMPTION	10 kW (kompresör dâhil) 10 kW (including compressor)
<b>HAVA GEREKSİNİMİ</b> AIR REQUIREMENT	500 lt /6-8 bar
<b>KULLANILAN AMBALAJ</b> PACKAGING USED	OPP/CPP - PET/AL - ve diğer lamineli filmler OPP/CPP - PET/AL - and other laminated films



Yastık Paket  
Pillow Package



Körüklü Paket  
Stan Up Package



Quadro Paket \*  
Quadro Package



Quadro Paket \*\*  
Quadro Package



Punch Slot Aska Deliği  
Pillow Package



Euro Slot Aska Deliği  
Pillow Package



El Geçmeli Paket  
Hand Punch

\* 4 Kenar Yapıştırma  
4 Edge Banding  
\*\* 5 Kenar Yapıştırma  
5 Edge Banding



**TEKNİK ÖZELLİKLER / TECHNICAL FEATURES**

<b>DOLUM SİSTEMİ</b>	Volumetrik ve terazili dolum sistemi(10-14)
<b>FILLING SYSTEM</b>	Volumetric and scale filling system (10-14)
<b>PAKETLENEN ÜRÜNLER</b>	Bakliyat
<b>PACKED PRODUCTS</b>	Pulses
<b>KAPASİTE</b>	35-45 pk/dk(Ürüne, ambalaja ve gramaja göre değişiklik gösterebilir.)
<b>CAPACITY</b>	35-45 pack/min (It may vary depending on the product, packaging and weight.)
<b>PAKET TİPLERİ</b> PACKAGE TYPES	Tuğla paket Brick package
<b>MAKİNA ÖLÇÜLERİ</b> (en x boy x yükseklik)	2000 x 4100 x 3600 mm (elevatör hariç)
<b>MACHINE DIMENSIONS</b> (width x length x height)	2000 x 4100 x 3600 mm (except elevator)
<b>AĞIRLIK</b> WEIGHT	3000 kg
<b>ELEKTRİK İHTİYACI</b> ELECTRICITY NEED	3x380V/50Hz
<b>ELEKTRİK TÜKETİMİ</b> ELECTRICITY CONSUMPTION	15 kW (kompresör dâhil) 15 kW (including compressor)
<b>HAVA GEREKSİNİMİ</b> AIR REQUIREMENT	1000 lt /10 bar
<b>KULLANILAN AMBALAJ</b> PACKAGING USED	OPP/CPP - PET/AL - ve diğer lamineli filmler OPP/CPP - PET/AL - and other laminated films



Tuğla Paket Ön  
Block Bottom Front



Tuğla Paket Arka  
Block Bottom Back

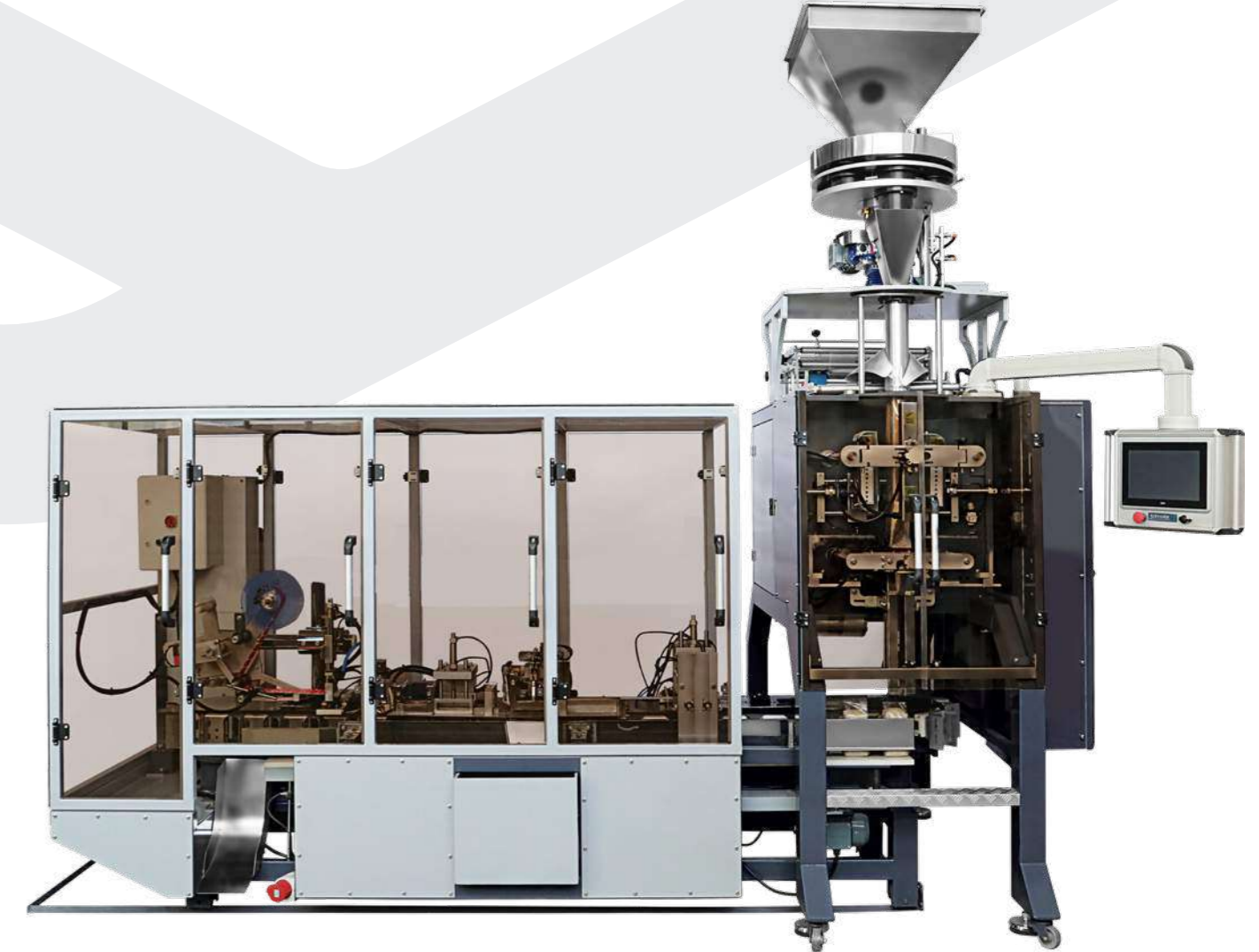

**VOLUMETRİK SİSTEM TAM OTOMATİK PAKETLEME MAKİNASI**  
**VOLUMETRIC SYSTEM FULL AUTOMATIC PACKAGING MACHINE**  
**MACHINE D'EMBALLAGE AUTOMATIQUE A SYSTEME VOLUMETRIQUE**  
**ПОЛНОСТЬЮ АВТОМАТИЧЕСКАЯ УПАКОВОЧНАЯ МАШИНА НА**  
**ОБЪЕМНОЙ СИСТЕМЕ**  
 ماكينة التعبئة أوتوماتيكية بنظام حجمي

technostar

**TPV-5000-VP**



**TPV-1000-SP**

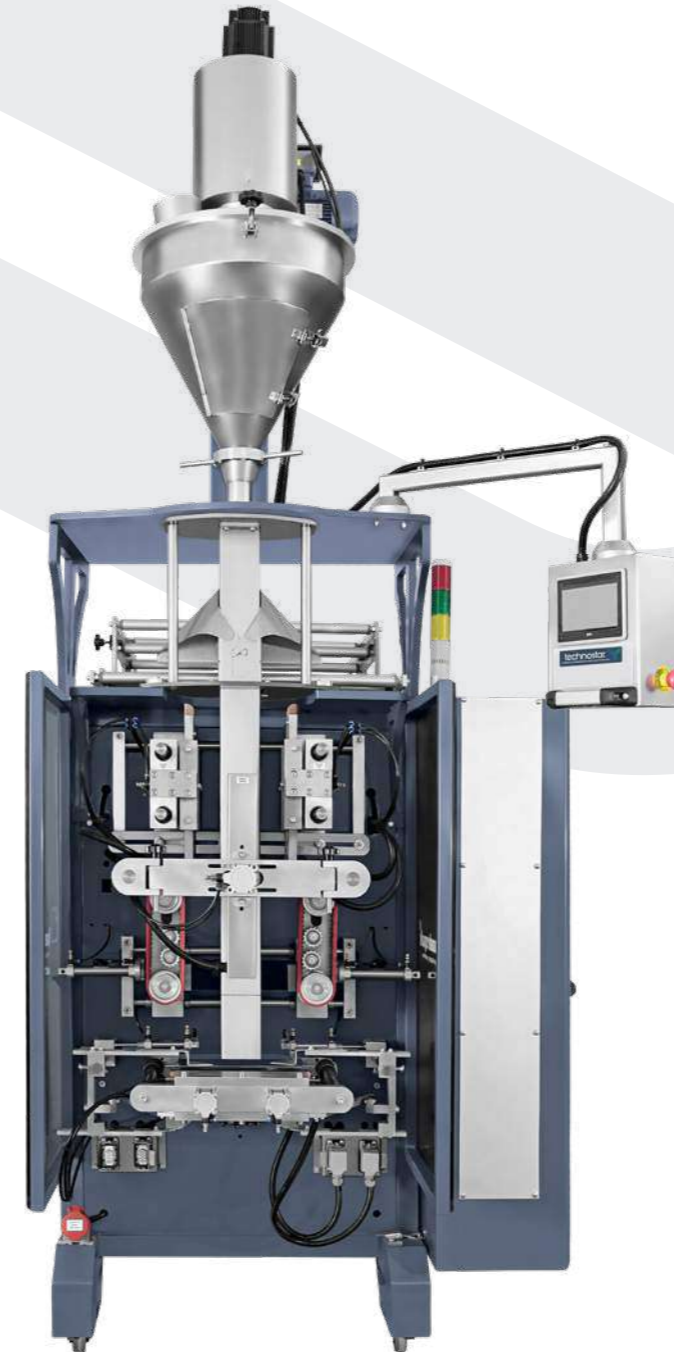

technostar

**VİDALI SİSTEM TAM OTOMATİK PAKETLEME MAKİNASI**  
**SCREW SYSTEM FULL AUTOMATIC PACKAGING MACHINE**  
**MACHINE D'EMBALLAGE AUTOMATIQUE A SYSTEME VIS**  
**ПОЛНОСТЬЮ АВТОМАТИЧЕСКАЯ УПАКОВОЧНАЯ МАШИНА НА**  
**ШНЕКОВОЙ СИСТЕМЕ**  
 برغي نظام أوتوماتيكي كامل ماكينة التعبئة والتغليف

**TEKNİK ÖZELLİKLER / TECHNICAL FEATURES**

<b>DOLUM SİSTEMİ</b> FILLING SYSTEM	Volumetrik dolum ünitesi Volumetric filling unit
<b>PAKETLENEN ÜRÜNLER</b> PACKED PRODUCTS	500 gr - 5000 gr Bakliyat 500 gr - 5000 gr Pulses
<b>KAPASİTE</b> CAPACITY	15-50 pk/dk (Ürüne, ambalaja ve gramaja göre değişiklik gösterebilir.) 15-50 pack/min (It may vary depending on the product, packaging and weight.)
<b>PAKET TİPLERİ</b> PACKAGE TYPES	Yastık, Körüklü, Quadro Paket Pillow, Gusseted, Quadro Package
<b>MAKİNA ÖLÇÜLERİ</b> (en x boy x yükseklik) MACHINE DIMENSIONS (width x length x height)	1750 x 2100 x 3000 mm (elevatör hariç) 1750 x 2100 x 3000 mm (except elevator)
<b>AĞIRLIK</b> WEIGHT	1400 kg
<b>ELEKTRİK İHTİYACI</b> ELECTRICITY NEED	3x380V/50Hz
<b>ELEKTRİK TÜKETİMİ</b> ELECTRICITY CONSUMPTION	10 kW (kompresör dâhil) 10 kW (including compressor)
<b>HAVA GEREKSİNİMİ</b> AIR REQUIREMENT	500 lt /6-8 bar
<b>KULLANILAN AMBALAJ</b> PACKAGING USED	OPP/CPP - PET/AL - PE+PE ve diğer lamineli filmler OPP/CPP - PET/AL - PE+PE and other laminated films



\* 4 Kenar Yapıştırma  
4 Edge Banding  
\*\* 5 Kenar Yapıştırma  
5 Edge Banding

**TEKNİK ÖZELLİKLER / TECHNICAL FEATURES**

<b>DOLUM SİSTEMİ</b> FILLING SYSTEM	Vidalı dolum sistemi Screw filling system
<b>PAKETLENEN ÜRÜNLER</b> PACKED PRODUCTS	20 gr - 1000 gr Tozlu Ürünler 20 gr - 1000 gr Baharat 20 gr - 1000 gr Zirai Gübre 1000 gr - 5000 gr Derz Dolgu 20 gr - 1000 gr Powdered Products 20 gr - 1000 gr Spice 20 gr - 1000 gr Agricultural Fertilizer 1000 gr - 5000 gr Joint Filler
<b>KAPASİTE</b> CAPACITY	25-50 pk/dk (Ürüne, ambalaja ve gramaja göre değişiklik gösterebilir.) 25-50 pack/min (It may vary depending on the product, packaging and weight.)
<b>PAKET TİPLERİ</b> PACKAGE TYPES	Yastık, Körüklü, Quadro Paket Pillow, Gusseted, Quadro Package
<b>MAKİNA ÖLÇÜLERİ</b> (en x boy x yükseklik) MACHINE DIMENSIONS (width x length x height)	1750 x 2100 x 3000 mm (helezon hariç) 1750 x 2100 x 3000 mm (except elevator)
<b>AĞIRLIK</b> WEIGHT	1500 kg
<b>ELEKTRİK İHTİYACI</b> ELECTRICITY NEED	3x380V/50Hz
<b>ELEKTRİK TÜKETİMİ</b> ELECTRICITY CONSUMPTION	10 kW (kompresör dâhil) 10 kW (including compressor)
<b>HAVA GEREKSİNİMİ</b> AIR REQUIREMENT	500 lt /6-8 bar
<b>KULLANILAN AMBALAJ</b> PACKAGING USED	OPP/CPP - PET/AL - ve diğer lamineli filmler OPP/CPP - PET/AL - and other laminated films

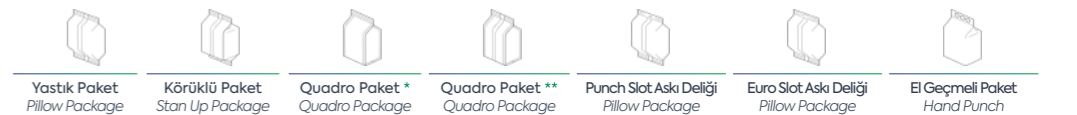

\* 4 Kenar Yapıştırma  
4 Edge Banding  
\*\* 5 Kenar Yapıştırma  
5 Edge Banding



**YARI OTOMATİK VİDALI PAKETLEME MAKİNASI**  
SEMI-AUTOMATIC SCREW PACKAGING MACHINE  
MACHINE D'EMBALLAGE SEMI AUTOMATIQUE A SYSTEME VIS  
ПОЛУАВТОМАТИЧЕСКАЯ УПАКОВОЧНАЯ МАШИНА НА  
ШНЕКОВОЙ СИСТЕМЕ  
ماكينه التعبئة برغي شبه أوتوماتيكية

technostar

## TPV-1000-SSP



### TEKNİK ÖZELLİKLER / TECHNICAL FEATURES

<b>DOLUM SİSTEMİ</b> FILLING SYSTEM	Vidalı dolum sistemi Screw filling system
<b>PAKETLENEN ÜRÜNLER</b> PACKED PRODUCTS	20-1000 gr tozlu ürünler ve 500-5000 gr tozlu ürünler 20-1000 gr powdered products and 500-5000 gr powdered products
<b>KAPASİTE</b> CAPACITY	8-20 pk/dk (Ürüne, ambalaja ve gramaja göre değişiklik göstermektedir.) 8-20 pack/min (It may vary depending on the product, packaging and weight.)
<b>PAKET TİPLERİ</b> PACKAGE TYPES	Hazır ambalajlar, pet şişeler, karton kutular vb. Prepackages, pet bottles, cardboard boxes, etc.
<b>MAKİNA ÖLÇÜLERİ</b> (en x boy x yükseklik) MACHINE DIMENSIONS (width x length x height)	600 x 800 x 2100 mm
<b>AĞIRLIK</b> WEIGHT	350 kg
<b>ELEKTRİK İHTİYACI</b> ELECTRICITY NEED	3x380V/50Hz
<b>ELEKTRİK TÜKETİMİ</b> ELECTRICITY CONSUMPTION	2 kW
<b>DOLUM MOTORU</b> AIR REQUIREMENT	Servo motor

## TPV-CTS-150

technostar

**TAM OTOMATİK CONTINUOUS PAKETLEME MAKİNASI**  
FULL AUTOMATIC CONTINUOUS PACKAGING MACHINE  
MACHINE D'EMBALLAGE AUTOMATIQUE A SYSTEME CONTINUE  
ПОЛНОСТЬЮ АВТОМАТИЧЕСКАЯ МАШИНА  
НЕПРЕРЫВНОЙ УПАКОВКИ  
ماكينه التعبئة وتغليف أوتوماتيكية بالكامل



### TEKNİK ÖZELLİKLER / TECHNICAL FEATURES

<b>DOLUM SİSTEMİ</b> FILLING SYSTEM	Multihead 20 Kefeli Dolum Sistemi Multihead 20 Scales Filling System
<b>PAKETLENEN ÜRÜNLER</b> PACKED PRODUCTS	Kuruyemiş, bakliyat, makarna, şekerleme, toz şeker, bisküvi, gofret, dondurulmuş ürünler, kurutulmuş meyve gibi taneli ürünler Grain products such as nuts, pulses, pasta, confectionery, granulated sugar, biscuits, wafers, frozen products, dried fruit
<b>KAPASİTE</b> CAPACITY	30 - 130 pk/dk (ürüne, paket tipine, ambalaja ve gramaja göre değişiklik gösterebilir.) Not: bu kapasite 20 kefelili dolum ünitesi için geçerlidir. 30 - 130 pack/min (It may vary depending on the product, packaging and weight.) Note: this capacity is valid for 20 scales filling unit.
<b>PAKET TİPLERİ</b> PACKAGE TYPES	Yastık, Körüklü, Pillow, Gusseted,
<b>MAKİNA ÖLÇÜLERİ</b> (en x boy x yükseklik) MACHINE DIMENSIONS (width x length x height)	2500 x 2100 x 4000 mm (elevatör hariç ölçüler) 2500 x 2100 x 4000 mm (dimensions excluding elevator)
<b>AĞIRLIK</b> WEIGHT	1400 kg
<b>ELEKTRİK İHTİYACI</b> ELECTRICITY NEED	3x380V/50Hz
<b>ELEKTRİK TÜKETİMİ</b> ELECTRICITY CONSUMPTION	14 kW
<b>HAVA GEREKSİNİMİ</b> AIR REQUIREMENT	500 lt /6-8 bar
<b>KULLANILAN AMBALAJ</b> PACKAGING USED	OPP/CPP - PET/AL OPP/CPP - PET/AL

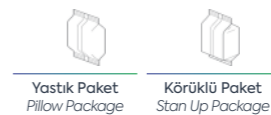

Yastık Paket  
Pillow Package

Körüklü Paket  
Stan Up Package

**YARI OTOMATİK 2 TERAZİLİ VİDALI PAKETLEME MAKİNASI**  
SEMI-AUTOMATIC SCREW FEEDING SYSTEM PACKAGING MACHINE  
WITH 2 SCALES  
MACHINE D'EMBALLAGE A VIS SEMI AUTOMATIQUE A DEUX BALANCES  
ПОЛУАВТОМАТИЧЕСКАЯ УПАКОВОЧНАЯ МАШИНА НА ШНЕКОВОЙ  
СИСТЕМЕ С 2 ВЕСАМИ  
ماكينه التعبئة برغي نصف أوتوماتيكية بميزانين

technostar

## TPV-1000-SSA



### TEKNİK ÖZELLİKLER / TECHNICAL FEATURES

DOLUM SİSTEMİ FILLING SYSTEM	2 terazili lineer - vidalı dolum sistemi Linear - screw filling system with 2 scales
PAKetlenen ÜRÜNLER PACKED PRODUCTS	20-1000 gr tozlu ürünler ve taneli ürün çeşitleri 20-1000 gr powdery products and granular product types
KAPASİTE CAPACITY	8-20 pk/dk (vidalı sistem için) 6-12 pk/dk (2 terazili sistem için) (gramaja göre değişiklik göstermektedir.)
PAKET TİPLERİ PACKAGE TYPES	Hazır ambalajlar, pet şişeler, karton kutular vb. Prepackages, pet bottles, cardboard boxes, etc.
MAKİNA ÖLÇÜLERİ(en x boy x yükseklik) MACHINE DIMENSIONS (width x length x height)	1500 x 900 x 2200 mm (elevatör hariç) 1500 x 900 x 2200 mm (except elevator)
AĞIRLIK WEIGHT	800 kg
ELEKTRİK İHTİYACI ELECTRICITY NEED	3x380V/50Hz
ELEKTRİK TÜKETİMİ ELECTRICITY CONSUMPTION	4 kW
HAVA GEREKSİNİMİ AIR REQUIREMENT	200 lt /6-8 bar

## TPV-5000-SWP

technostar

**YARI OTOMATİK 2 TERAZİLİ PAKETLEME MAKİNASI**  
SEMI-AUTOMATIC 2 SCALE PACKAGING MACHINE  
MACHINE D'EMBALLAGE SEMI AUTOMATIQUE A DEUX BALANCES  
ПОЛУАВТОМАТИЧЕСКАЯ УПАКОВОЧНАЯ МАШИНА С 2 ВЕСАМИ  
ماكينه التعبئة شبه الأوتوماتيكية ذات المقياس 2



### TEKNİK ÖZELLİKLER / TECHNICAL FEATURES

DOLUM SİSTEMİ FILLING SYSTEM	2 terazili lineer dolun ünitesi Linear filling unit with 2 scales
PAKetlenen ÜRÜNLER PACKED PRODUCTS	200 gr - 1000 gr Kuruyemiş 500 gr - 5000 gr Bakliyat - Toz Şeker / Toz Deterjan 3000 gr - 10000 gr Toz Deterjan / Kedi Kumu
KAPASİTE CAPACITY	200 gr - 1000 gr Nuts 500 gr-5000 gr Pulses - Powdered Sugar / Powdered Detergent 3000 gr - 10000 gr Powder Detergent / Cat Litter
PAKET TİPLERİ PACKAGE TYPES	6-12 pk/dk (Ürüne, ambalaja ve gramaja göre değişiklik gösterebilir.)
MAKİNA ÖLÇÜLERİ(en x boy x yükseklik) MACHINE DIMENSIONS (width x length x height)	6-12 pack/min (It may vary depending on the product, packaging and weight.)
AĞIRLIK WEIGHT	Hazır ambalaj, pet şişe, karton kutu vb. Prepackages, pet bottles, cardboard boxes, etc.
ELEKTRİK İHTİYACI ELECTRICITY NEED	810 x 900 x 2200 mm (elevatör hariç) 810 x 900 x 2200 mm (except elevator)
ELEKTRİK TÜKETİMİ ELECTRICITY CONSUMPTION	450 kg
HAVA GEREKSİNİMİ AIR REQUIREMENT	3x380V/50Hz
	8 kW (kompresör dâhil) 8 kW (including compressor)
	300 lt /6-8 bar



Z TİPİ ELEVATÖR  
Z TYPE ELEVATOR



SİRAL HELEZON  
SPIRAL HELICAL

KONVEYÖR BANT  
CONVEYOR BELT



QUADRO YAKA  
QUADRO COLLAR



DÜZ YAKA  
FLAT COLLAR

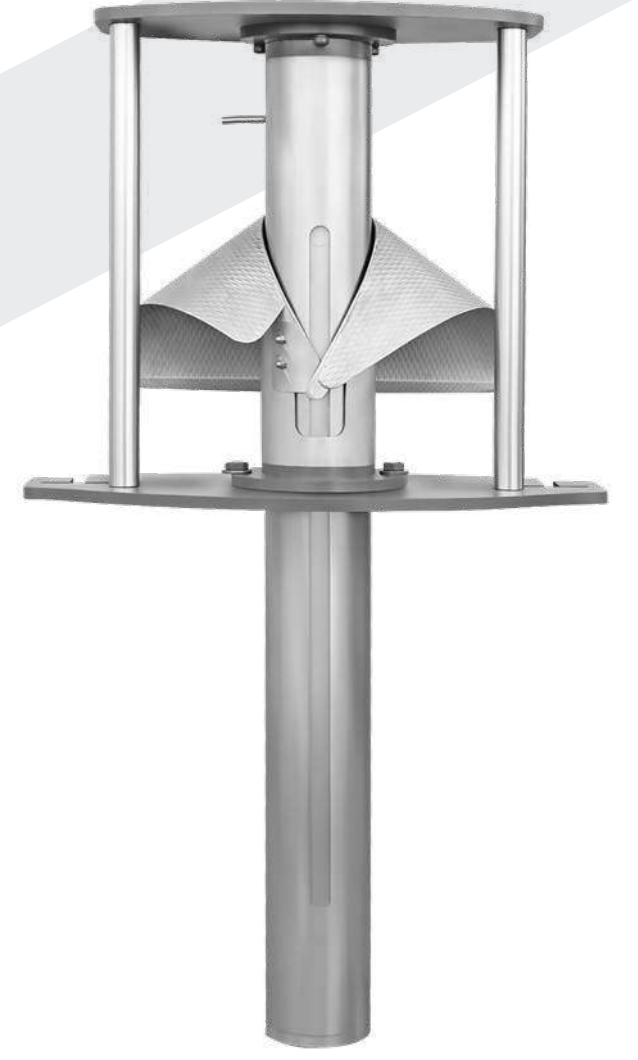

YUVARLAK YAKA  
ROUND COLLAR

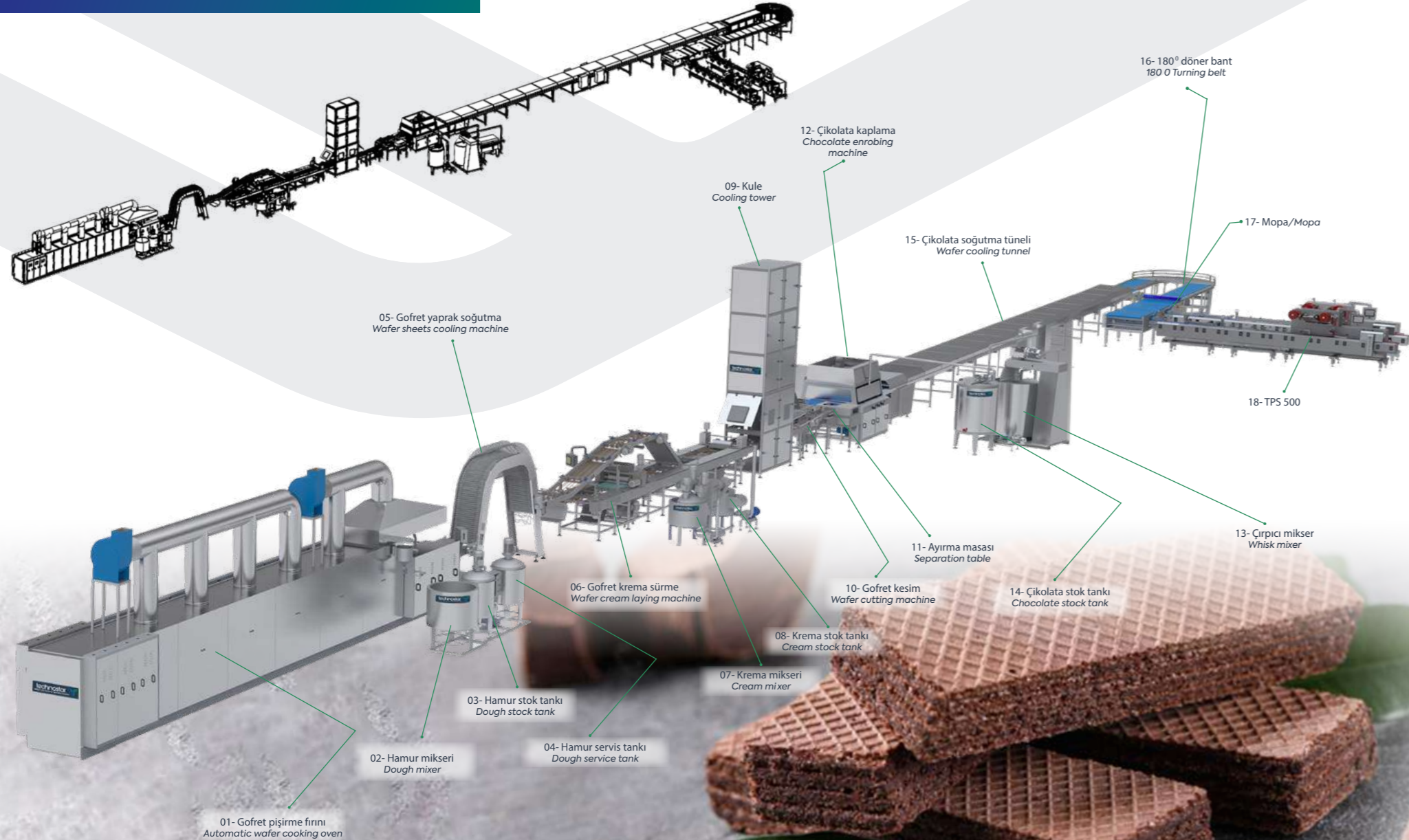

Not: Her bir hat için mutfak ekipmanları değişmektedir.  
 Note: Kitchen equipment varies for each line



**TEKNİK ÖZELLİKLER / TECHNICAL FEATURES**

KALIP SAYISI NUMBER OF MOLDS	60
KALIP EBADI MOLD SIZE	350 mm x 500 mm
KAPLAMA COATING	KROM-NİKEL CHROME-NICKEL
KAPASİTE CAPACITY	30 yaprak/dakika 30 sheets/minute
TÜKETİM (Gaz) CONSUMPTION (Gas)	40-55 m3/saat 40-55 m3/hour
GİRİŞ GÜCÜ ELECTRIC POWER	16,5 kW
GERİLİM VOLTAGE	380V – 3 Faz N Pe – 50Hz 380V – 3 Phases N Pe – 50Hz
GEREKLİ HAVA BASINCI AIR PRESSURE	6 Bar

**ÜRÜN ÖZELLİKLERİ**

Mutfak ünitesinden pompalar vasıtası ile malzemenin gofret kalıplarının üstüne döküldüğü ve sonrasında pişme prosesinin gerçekleştiği bölümdür. Gofret yaprakları bu fırınlarda tam otomatik olarak el değmeden hijyenik bir şekilde bir sonraki işleme hazır hale getirilebilir.

**PRODUCT FEATURES**

It is the section where the material is poured onto the wafer molds by means of pumps from the kitchen unit and then the baking process takes place. In these ovens, wafer sheets can be prepared for the next process in a hygienic way without human touch, fully automatically.

**YAPRAK SOĞUTMA MAKİNASI**  
 WAFER SHEETS COOLING MACHINE  
 MACHINE DE REFOIDISSEMENT FEUILLES DE GAUFRETTES  
 МАШИНА ДЛЯ ОХЛАЖДЕНИЯ ВАФЕЛЬНЫХ ЛИСТОВ  
 ماكينة تبريد الأوراق

technostar



**TEKNİK ÖZELLİKLER / TECHNICAL FEATURES**

SOĞUTMA FONKSİYONU COOLING FEATURE	Yarı Hermetik Tip 7hp Soğutucu ve Hava Kondenser R404a Semihermetic Type 7 hp Cooling & Air Condenser R404a
SOĞUTMA GAZI COOLING GAS	Freon R404a
BUHARLAŞTIRICI FONKSİYONU EVAPORATOR FEATURE	Dikey tip soğutma fanı, Defrost ve kondenseri buharlaştırıcı Vertical Type Special Produced Coolant Fan, Defrost And Condensate Evaporator
SOĞUTMA DERECE KAPASİTESİ COOLING TEMPERATURE CAPACITY	2 Adet Soğutma Ünitesi, 2x13.410=26.820 watt = 18.000 kcal/H 2 Pcs Coolant Units, 2x13.410=26.820 watt = 18.000 kcal/H
SOĞUTMA SİSTEMİ EKİPMANLARI COOLING SYSTEM EQUIPMENT	2 Adet 7hp Kompresör, 2 Adet Çift Soğutma Fanı, Termostatik Genleşme Valfleri, Isı, solenoid valf ile yoğunlaşma buharlaşmasının dijital kontrolü. 2 Pcs 7hp Compressor, 2 Pcs Double Coolant Fans, Thermostate Expantion Valves, Digital Control Of Condensate Evaporator By Heat, Solenoid Valve.
SOĞUTMA SIVISI VERİMLİLİĞİ COOLANT EFFICIENCY	Cop = 2.19 (Kompresör performans katsayısı) Cop = 2.19 (Coefficient of Compressor Performance)
GÜÇ POWER	Yaklaşık 21 kw. Approximately 21 kw.
GENİŞLİK WIDTH	1.500 mm
UZUNLUK LENGHT	3.800 mm
YÜKSEKLİK HEIGHT	4.200 mm
AĞIRLIK WEIGHT	2.800 kg.

**TEKNİK ÖZELLİKLER / TECHNICAL FEATURES**

GİRİŞ GÜCÜ ELECTRIC POWER	1,7 kW
MALZEME MOLD SIZE	304 paslanmaz Krom – Nikel 304 Stainless Chrome – Nickel
GERİLİM VOLTAGE	380V – 3 Faz N Pe – 50Hz 380V – 3 Phases N Pe – 50Hz

**ÜRÜN ÖZELLİKLERİ**

Gofret fırınından çıkan gofret yapraklarının sıcaklığını ortam sıcaklığına düşürmek için tasarlanmış makinedir. Gofret yaprakları, yaprak soğutma makinasına otomatik olarak beslenir. Fırın ile senkronize olarak çalışır ve PLC kontrol panelinden hızı ayarlanabilir.

**PRODUCT FEATURES**

It is a machine designed to reduce the temperature of the wafer sheets coming out of the wafer oven to the ambient temperature. Wafer sheets are fed into the sheet cooling machine automatically. It works synchronously with the oven and its speed can be adjusted from the PLC control panel.

**BLOK GOFRET KULE SOĞUTUCU**  
 WAFER BOOK COOLING TOWER  
 TOUR DE REFOIDISSEMENT DE BLOC DE GAUGRETTES  
 ОХЛАЖДАЮЩАЯ КАМЕРА ДЛЯ ВАФЕЛЬНЫХ БЛОКОВ  
 مبرد برج بولك الويفر



**ÜRÜN ÖZELLİKLERİ**

Sıcak olarak gofret bloğunun arasına sürülen kremayı soğutmak ve kesimden önce gofret bloğuna gevreklik kazandırmak için kullanılan soğutma bölümüdür. Şase, kapaklar ve konveyör sistemi tamamen paslanmaz çelikten üretilmiştir. Özel tasarımı sayesinde bakımı ve temizliği oldukça basittir.

**PRODUCT FEATURES**

It is the cooling section which is used to cool the cream applied between the wafer block and to give the wafer block the brittle before cutting. The chassis, covers and conveyor system are completely made of stainless steel. Thanks to its special design, maintenance and cleaning is very simple.

Not: Her bir hat için mutfak ekipmanları değişmektedir.  
 Note: Kitchen equipment varies for each line

technostar

**GOFRET KREMA SÜRME MAKİNASI**  
 WAFER CREAM LAYING MACHINE  
 MACHINE A ETALER CREME DE GAUFRETTES  
 МАШИНА ДЛЯ УКЛАДКИ ВАФЕЛЬНЫХ КРЕМОВ  
 ماكينة وضع الكريمة بالرفائق

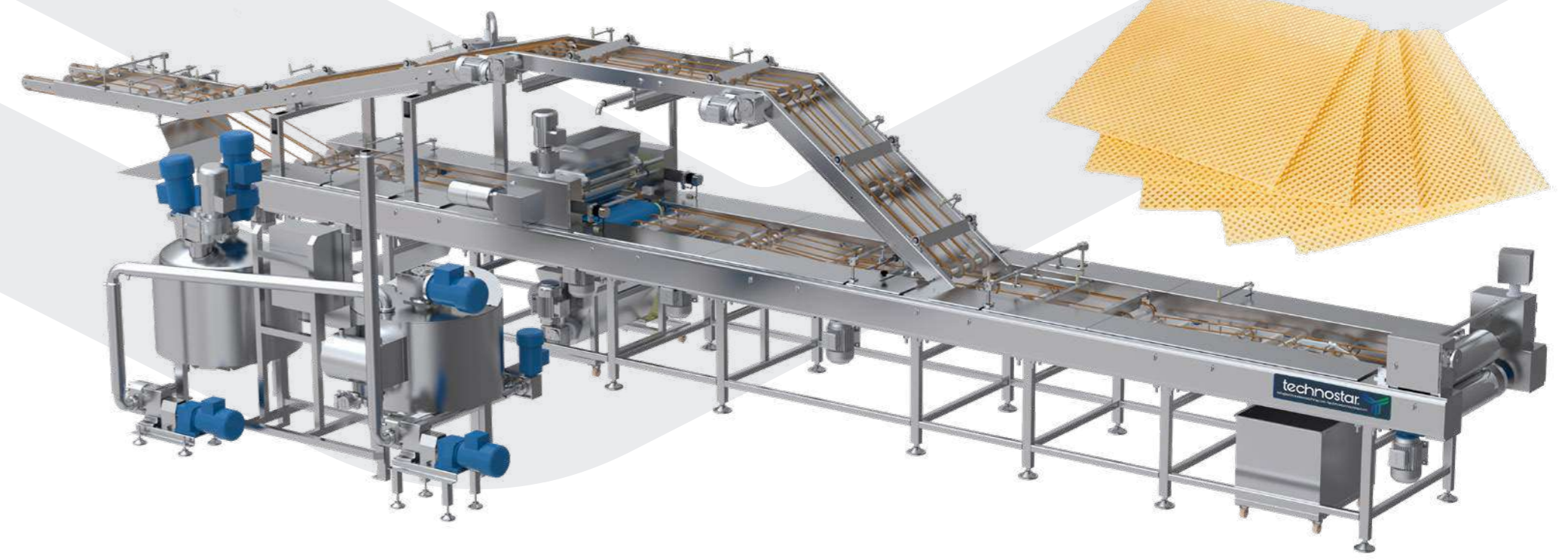

**TEKNİK ÖZELLİKLER / TECHNICAL FEATURES**

GİRİŞ GÜCÜ ELECTRIC POWER	20,65 kW
MALZEME MOLD SIZE	304 paslanmaz Krom – Nikel 304 Stainless Chrome – Nickel
GERİLİM VOLTAGE	380V – 3 Faz N Pe – 50Hz 380V – 3 Phases N Pe – 50Hz

**ÜRÜN ÖZELLİKLERİ**

Gofret yaprak soğutma makinasından çıkan gofret yapraklarının arasına krema sürümü yapan makinedir. Tek renk veya birden fazla renk çalışma olanağı sunar. Krema sürüm tamburlarının beslemesi pompalar yardımı ile yapılır ve tamamen otomatiktir. Sürüm tamburları dönme esnasında yaprağın konumuna göre yukarı aşağı hareket ederek pürüzsüz sürüm yapma olanağı sağlar. Krema kalınlığı manuel olarak ayarlanabilir.

**PRODUCT FEATURES**

It is the machine that makes cream spread between the wafer sheets coming out of the wafer sheet cooling machine. It offers the opportunity to work in one color or more than one color. The feeding of cream delivery drums is made with the help of pumps and is fully automatic. Plowing drums move up and down according to the position of the leaf during rotation, allowing smooth plowing. Cream thickness can be adjusted manually.

**GOFRET SOĞUTMA TÜNELİ**  
WAFFER COOLING TUNNEL  
TUNNEL DE REFROIDISSEMENT DE GAUFRETTES  
ОХЛАЖДАЮЩИЙ ТУННель ДЛЯ ВАФЕЛЬНЫХ БЛОКОВ  
نفق التبريد بالرقائق

technostar

Not: Her bir hat için mutfak ekipmanları değişmektedir.  
Note: Kitchen equipment varies for each line



**TEKNİK ÖZELLİKLER / TECHNICAL FEATURES**

GİRİŞ GÜCÜ ELECTRIC POWER	15,2 kW
SOĞUTMA GRUBU KAPASİTESİ COOLING GROUP CAPACITY	18.000 kcal / h
KULANILAN MALZEMELER USED MATERIALS	304 paslanmaz Krom-Nikel 304 Stainless Chrome - Nickel
YÜKSEKLİK HEIGHT	3900 mm

**ÜRÜN ÖZELLİKLERİ**

Sıcak olarak gofret bloğunun arasına sürülen kremayı soğutmak ve kesimden önce gofret bloğuna gevreklik kazandırmak için kullanılan soğutma bölümüdür. Özel tasarımı sayesinde bakımı ve temizliği oldukça basittir.

**PRODUCT FEATURES**

It is the cooling section used to cool the cream that is spread between the hot wafer block and to give the wafer block a crispiness before cutting. Thanks to its special design, it is very easy to maintain and clean.

Not: Her bir hat için mutfak ekipmanları değişmektedir.  
Note: Kitchen equipment varies for each line

technostar

**GOFRET KESİM MAKİNASI**  
WAFFER CUTTING MACHINE  
MACHINE DE DECOUPE DE GAUFRETTES  
МАШИНА ДЛЯ РЕЗКИ ВАФЕЛЬ  
ماكينة قطع الويفر



**ÜRÜN ÖZELLİKLERİ**

Blok gofret soğutma tüneline çıkan gofret bloklarını istenilen ebatlarda kesme işlemi yapan makinedir. Kesilen gofretler tek tek ve ya blok olarak paketleme makinasına askerler ile beslenir.

**PRODUCT FEATURES**

It is the machine that cuts the wafer blocks coming out of the block wafer cooling tower into desired sizes. The cut wafers are fed to the packaging machine individually or as a block by cleats.

**TEKNİK ÖZELLİKLER / TECHNICAL FEATURES**

GİRİŞ GÜCÜ ELECTRIC POWER	2,2 kW
SOĞUTMA GRUBU KAPASİTESİ COOLING GROUP CAPACITY	15 Kesim / Dk
KULANILAN MALZEMELER USED MATERIALS	304 Krom

**ISKARTA DEĞİRMENİ**  
DISCARD MILL  
MOULIN A REBUT  
УТИЛИЗАТОР  
تجاهل

technostar

Not: Her bir hat için mutfak ekipmanları değişmektedir.  
Note: Kitchen equipment varies for each line

technostar

**TAHIL BAR ÜRETİM HATTI**  
CEREAL BARS PRODUCTION LINE  
LIGNE DE PRODUCTION DE BARRES CEREALES  
ЛИНИЯ ПРОИЗВОДСТВА ЗЕРНОВЫХ БАТОНЧИКОВ  
خط إنتاج قضبان الحبوب

**TEKNİK ÖZELLİKLER / TECHNICAL FEATURES**

GİRİŞ GÜCÜ ELECTRIC POWER	8,5 kW
SOĞUTMA GRUBU KAPASİTESİ COOLING GROUP CAPACITY	150
KULLANILAN MALZEMELER USED MATERIALS	Nikelaj Kaplama – Bıçaklar Çelik Nickelage Plating – Steel Blades
İNCELTME KAPASİTESİ THINNING CAPACITY	160- 170 MIKRON / MICRON

**ÜRÜN ÖZELLİKLERİ**

Gofret iskartalarının çekilerek tekrar kullanılmasını sağlayan makinedir. Helezonlu ve bıçaklı tip değirmendir. Iskarta değirmeni, kesimde ve diğer gofret ekipmanlarında elde edilen ıskarta ürünü çekerek, gofret kremasının hazırlanmasında kullanılır.

**PRODUCT FEATURES**

It is the machine that allows the wafer scraps to be withdrawn and reused. It is a spiral and blade type mill. The reject mill is used in the preparation of wafer cream by pulling the discarded product from the cutting and other wafer equipment.

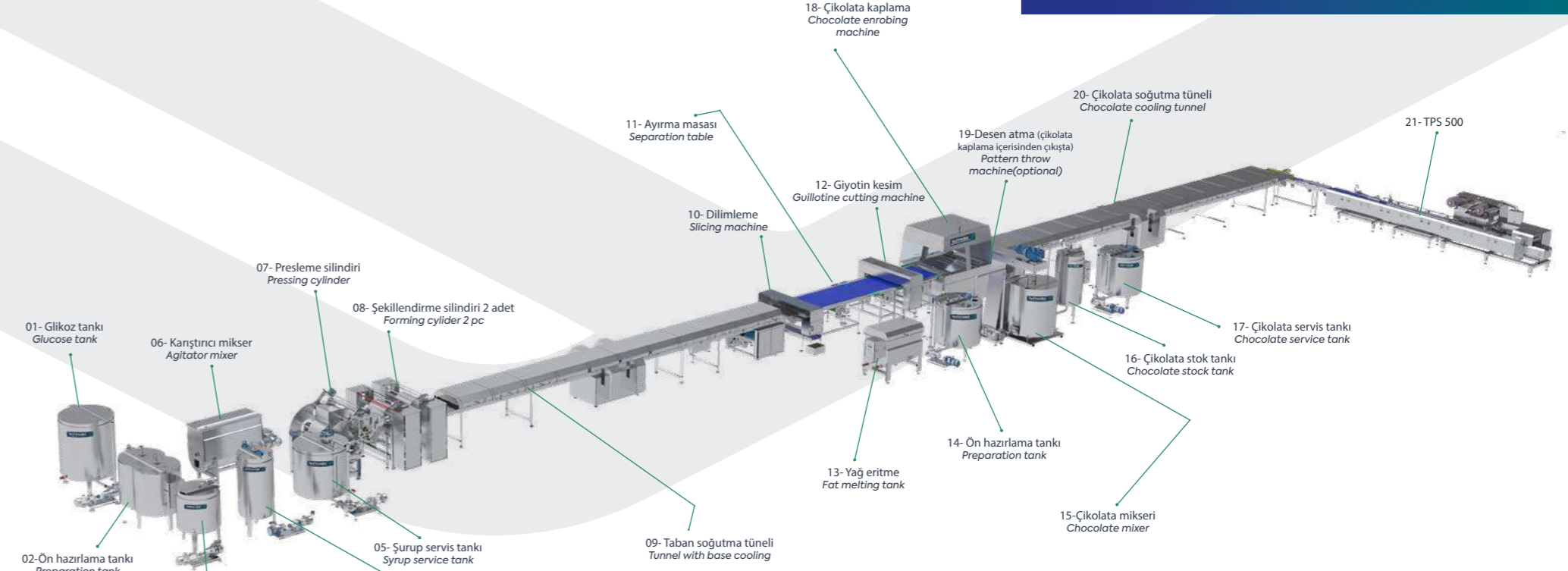

**NUGA KAREMEL- KROKAN ÜRETİM HATTI**  
NOUGAT CARAMEL-CROQUANT PRODUCTION LINE  
LIGNE DE PRODUCTION DE NOUGATS CARAMEL ET CROQUANTS  
ЛИНИЯ ПРОИЗВОДСТВА НУГОВЫХ БАТОНЧИКОВ  
خط إنتاج نوجا کروکان

technostar

technostar

**MARSHMALLOW ÜRETİM HATTI**  
MARSHMALLOW PRODUCTION LINE  
LIGNE DE PRODUCTION DE MARSHMALLOW  
ЛИНИЯ ПРОИЗВОДСТВА ЗЕФИРА  
خط إنتاج مارشمیلو

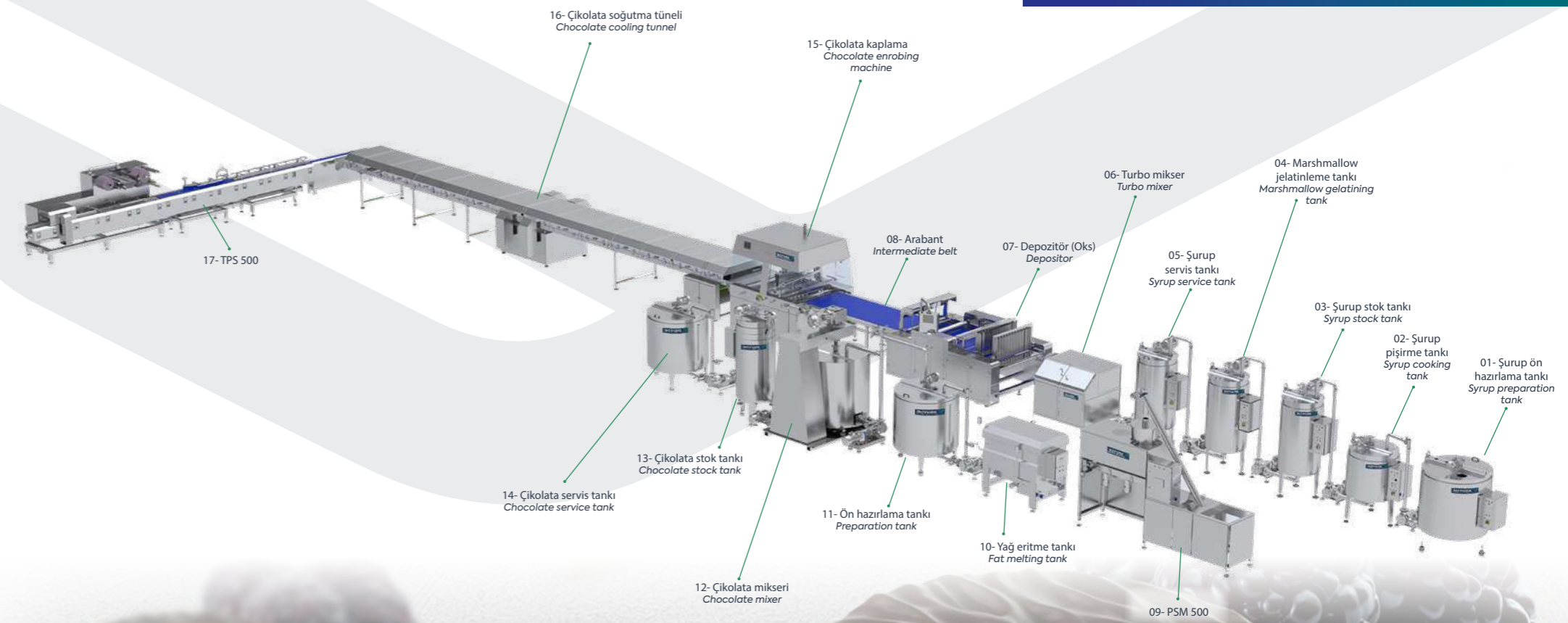
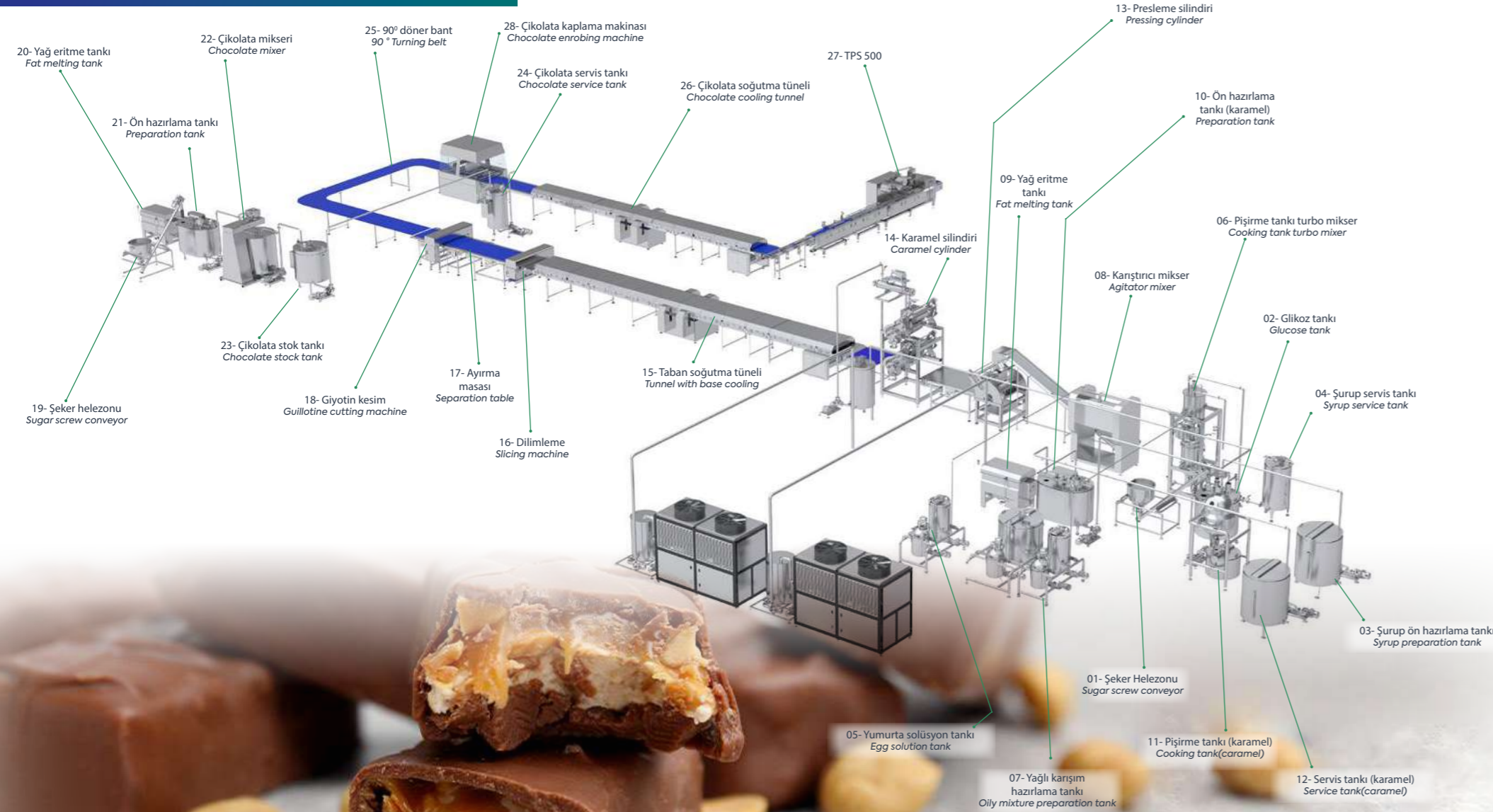



GLİKOZ TANKI  
GLUCOSE TANK  
CUVE DE GLUCOSE  
ГЛЮКОЗНЫЙ БАК  
خزان الجلوكوز

technostar



### ÜRÜN ÖZELLİKLERİ

Üretilecek olan ürünü hazırlamak amacıyla glikoz ürünü bu tank içerisinde belirli bir sıcaklıkta kullanıma hazır bir şekilde bekletilir. İstenilen tanka pompalar vasıtasıyla aktarılır.

### PRODUCT FEATURES

In order to prepare the product to be produced, the glucose product is kept in this tank at a certain temperature, ready for use. It is transferred to the desired tank by means of pumps.

TEKNİK ÖZELLİKLER TECHNICAL FEATURES	
VOLTAJ VOLTAGE	380V-3 Faz N Pe 380V-3 Phases N Pe
FREKANS FREQUENCY	50 Hz
ŞASE CHASSIS	AISI304
ELEKTRİK GÜCÜ ELECTRIC POWER	8.2 kW
KAPASİTE CAPACITY	500 kg
MOTOR SAYISI NUMBER OF MOTOR	2

### ÜRÜN ÖZELLİKLERİ

Üretilecek olan ürünler için gerekli olan hammaddeleri homojen bir şekilde karıştırıp sıvı hale getiren makinedir. Gövde ısıtma sistemi merkezi sıcak su ile sağlanmaktadır. Tartı ünitesi bulunmaktadır.

### PRODUCT FEATURES

It is a machine that homogeneously mixes and liquefies the raw materials required for the products to be produced. Body heating system is provided with central hot water. There is a weighing unit.

TEKNİK ÖZELLİKLER TECHNICAL FEATURES	
VOLTAJ VOLTAGE	380V-3 Faz N Pe 380V-3 Phases N Pe
FREKANS FREQUENCY	50 Hz
ŞASE CHASSIS	AISI304
ELEKTRİK GÜCÜ ELECTRIC POWER	10 kW
KAPASİTE CAPACITY	500 kg
MOTOR SAYISI NUMBER OF MOTOR	2

ÖN HAZIRLAMA TANKI  
PREPARATION TANK  
CUVE DE PREPARATION  
ПОДГОТОВИТЕЛЬНЫЙ РЕЗЕРВУАР  
خزان التحضير



PİŞİRME TANKI  
COOKING TANK  
CUVE DE CUISSON  
ВАРОЧНЫЙ РЕЗЕРВУАР  
خزان الطبخ

### ÜRÜN ÖZELLİKLERİ

Üretilecek olan ürünler için gerekli olan hammaddeyi pişiren ve stok tankına aktaran tanktır. Buhar ile pişirme yapar. Pişirme sıcaklığına ulaşınca otomatik olarak işlemi sonlandırır. Sistem sürekli veya kesintisiz ürün işleme yapabilir. Ürünün daha hızlı pişmesi ve yanmaması için özel dizayn edilmiş karıştırıcı ve sıyrıcıları mevcuttur. Sistem sürekli veya kesintili ürün işleme yapabilir.

### PRODUCT FEATURES

It is the tank that cooks the raw materials required for the products to be produced and transfers them to the stock tank. It cooks with steam. It automatically ends the process when it reaches the cooking temperature. The system can perform continuous or uninterrupted product processing. Specially designed mixers and scrapers are available for the product to cook faster and not burn. The system can perform continuous or intermittent product processing.

TEKNİK ÖZELLİKLER TECHNICAL FEATURES	
VOLTAJ VOLTAGE	380V-3 Faz N Pe 380V-3 Phases N Pe
FREKANS FREQUENCY	50 Hz
ŞASE CHASSIS	AISI304
ELEKTRİK GÜCÜ ELECTRIC POWER	13 kW
KAPASİTE CAPACITY	300 kg
MOTOR SAYISI NUMBER OF MOTOR	2
BUHAR BASINCI STEAM PRESSURE	600kPa

Not: Her bir hat için mutfak ekipmanları değişmektedir.  
Note: Kitchen equipment varies for each line

technostar



SERVİS TANKI  
SERVICE TANK  
CUVE DE SERVICE  
СЕРВИСНЫЙ РЕЗЕРВУАР  
خزان الخدمة

### ÜRÜN ÖZELLİKLERİ

Üretilecek olan ürünler için gerekli olan hammaddenin pişirildikten sonra stoklandığı tanktır. Ürün kullanılmak istenildiğinde pompalar vasıtasıyla pişirme ünitesine aktarılır. Ürün sıcaklığı bu tankta eşanjör ve çiller ile istenilen sıcaklığa ayarlanmaktadır.

### PRODUCT FEATURES

It is the tank where the raw materials required for the products to be produced are transferred to be used after cooking and stocking. When the product is desired to be used, it is transferred to the cooking unit by means of pumps. The product temperature is adjusted to the desired temperature with the heat exchanger and chiller in this tank.

TEKNİK ÖZELLİKLER TECHNICAL FEATURES	
VOLTAJ VOLTAGE	380V-3 Faz N Pe 380V-3 Phases N Pe
FREKANS FREQUENCY	50 Hz
ŞASE CHASSIS	AISI304
ELEKTRİK GÜCÜ ELECTRIC POWER	10 kW
KAPASİTE CAPACITY	500 kg
MOTOR SAYISI NUMBER OF MOTOR	2

technostarmachine.com

technostarmachine.com

KARIŞTIRICI MİKSER  
AGITATOR MIXER  
AGITATEUR MIXEUR  
МИКСЕР  
خلاط

technostar

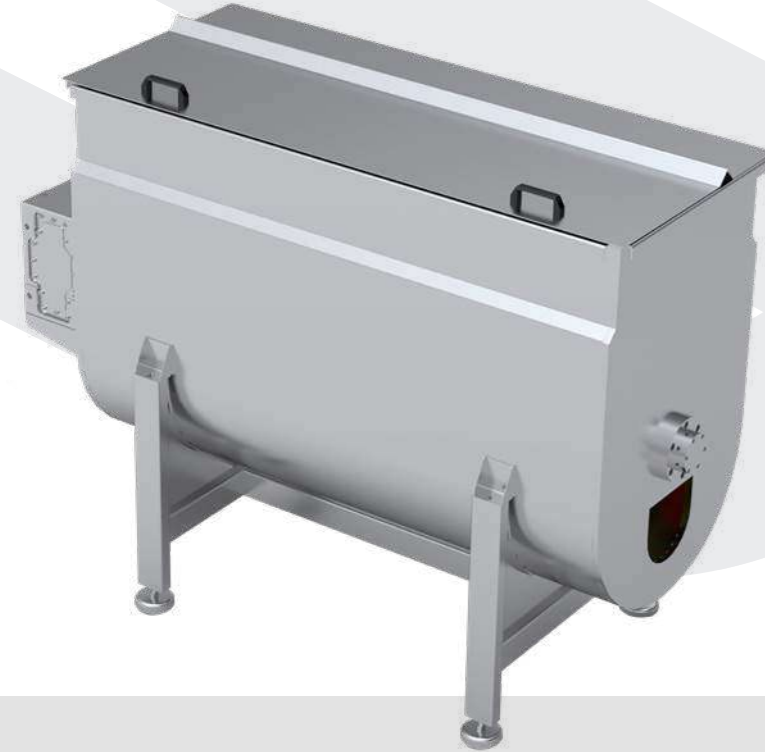

### ÜRÜN ÖZELLİKLERİ

Piştirilmiş ve havalandırılmış ürüne son olarak yağlı solüsyonunun homojen bir şekilde karıştırılmasını sağlayan makinedir. Karıştırıcı çift yönde çalışmaktadır.

### PRODUCT FEATURES

This machine provides a homogeneous mixing of the oily solution to the cooked and ventilated product. The mixer works in two directions.

PRESLEME SİLİNDİRİ  
PRESSING CYLINDER  
CYLINDRE DE PRESSAGE  
ПРЕССОВЫЙ ЦИЛИНДР  
اسطوانة الضغط



### ÜRÜN ÖZELLİKLERİ

Şurup ile homojen bir şekilde karışmış hamuru; ön soğutulmasına gerek kalmadan direkt olarak silindir haznesine beslenmesine ve şekil verilmesine imkân sağlar. Hem soğutma hem de şekil verme tek makina ile tamamlanır. Ürün kalınlığını kolay ayarlayabilir.

### PRODUCT FEATURES

The dough mixed homogeneously with the syrup; It allows it to be fed and shaped directly into the cylinder chamber without the need for pre-cooling. Both cooling and shaping are completed with a single machine. It can easily adjust the thickness of the product.

### TEKNİK ÖZELLİKLER TECHNICAL FEATURES

VOLTAJ VOLTAGE	380V-3 Faz N Pe 380V-3 Phases N Pe
FREKANS FREQUENCY	50 Hz
ŞASE CHASSIS	AISI304
ELEKTRİK GÜCÜ ELECTRIC POWER	1 kW
KAPASİTE CAPACITY	300kg/saat 300kg/hour
MOTOR SAYISI NUMBER OF MOTOR	2

technostar



ŞEKİLLENDİRME SİLİNDİRİ  
FORMING CYLINDER  
CYLINDRE DE FORMAGE  
ФОРМОВОЧНЫЙ ЦИЛИНДР  
تشكيل الاسطوانة

### TEKNİK ÖZELLİKLER TECHNICAL FEATURES

VOLTAJ VOLTAGE	380V-3 Faz N Pe 380V-3 Phases N Pe
FREKANS FREQUENCY	50 Hz
ŞASE CHASSIS	AISI304
ELEKTRİK GÜCÜ ELECTRIC POWER	0.37 kW
KAPASİTE CAPACITY	300kg/saat 300kg/hour
MOTOR SAYISI NUMBER OF MOTOR	1

### ÜRÜN ÖZELLİKLERİ

Ürüne son kalınlığını veren makinamızdır. Hem soğutma hem de şekil verme tek makina ile tamamlanır. Presleme silindiri ürün kalınlığını kolay ayarlayabilir. Ürün yapışmasının önüne geçmek için özel yağlama sistemi üzerinde mevcuttur.

### PRODUCT FEATURES

It is the machine that gives the final thickness to the product. Both cooling and shaping are completed with a single machine. The pressing roller can easily adjust the product thickness. It is available on a special lubrication system to prevent product sticking.



**TABAN SOĞUTMALI SOĞUTMA TÜNELİ**  
TUNNEL WITH BASE COOLING  
TUNNEL AVEC REFRROIDISSEMENT PAR SOL  
ОХЛАЖДАЮЩИЙ ТУННЕЛЬ С НАПОЛЬНЫМ ОХЛАЖДЕНИЕМ  
نفق التبريد مع قاعدة التبريد

technostar

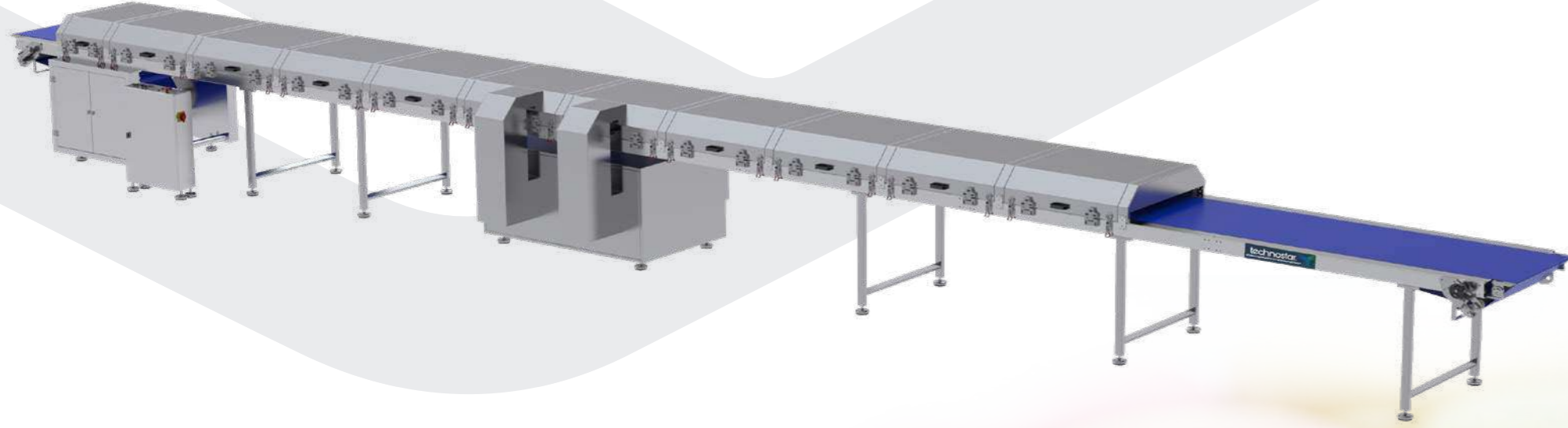

TEKNİK ÖZELLİKLER TECHNICAL FEATURES	
VOLTAJ VOLTAGE	380V-3 Faz N Pe 380V-3 Phases N Pe
FREKANS FREQUENCY	50 Hz
ŞASE CHASSIS	AISI304
ELEKTRİK GÜCÜ ELECTRIC POWER	9 kW
KAPASİTE CAPACITY	500kg/saat 500kg/hour
MOTOR SAYISI NUMBER OF MOTOR	1
HAVA AIR PRESSURE	6 Bar

### ÜRÜN ÖZELLİKLERİ

Soğutma tüneli içerisine aldığı ürünün sıcaklığını istenilen değerlere düşürmek için kullanılan poliüretan bant ile paslanmaz malzemelerden üretilen bir makinedir. Tünel PLC kontrollü olup tüm kumandaları çikolata kaplama makinası üzerindeki dokunmatik ekrandan yapılmaktadır.

### PRODUCT FEATURES

It is a machine made of stainless materials with a polyurethane belt used to reduce the temperature of the product inside the cooling tunnel to the desired values. The tunnel is PLC controlled and all controls are made from the touch screen on the chocolate coating machine.



**DİLİMLEME MAKİNASI**  
SLICING MACHINE  
MACHINE A TRANCHER  
ЛОМТЕРЕЗКА  
ماكينة التقطيع

technostar



### ÜRÜN ÖZELLİKLERİ

Şekil verilmiş ve ideal şekilde soğutulmuş, halı şeklinde serilmiş hamurları dilimleyerek fitil haline getiren makinedir. Dondurulmuş ürünleri istenilen genişlikte kesmeyi sağlar.

### PRODUCT FEATURES

It is a machine that slices the dough that has been shaped and ideally cooled, laid in the form of carpet, and turns it into a roving. It enables to cut frozen products in desired width.

TEKNİK ÖZELLİKLER TECHNICAL FEATURES	
VOLTAJ VOLTAGE	380V-3 Faz N Pe 380V-3 Phases N Pe
FREKANS FREQUENCY	50 Hz
ŞASE CHASSIS	AISI304
ELEKTRİK GÜCÜ ELECTRIC POWER	2 kW
KAPASİTE CAPACITY	500kg/saat 500kg/hour
MOTOR SAYISI NUMBER OF MOTOR	3



**AYIRMA MASASI**  
SEPARATION TABLE  
TABLE DE SEPARATION  
РАЗДЕЛОЧНЫЙ СТОЛ  
طاولة الفصل

### ÜRÜN ÖZELLİKLERİ

Dilimlenmiş olan ürünün aralarını açabilmek için ayırma masası kullanılır. Her bir ürün için kullanılacak olan bant farklılık göstermektedir. Ürün ölçüleri değişeceği zaman üst tabla kolay değiştirilecek biçimde tasarlanmıştır. Ürün bandı gıdaya uygun poliüretan malzemeden üretilmektedir.

### PRODUCT FEATURES

A separating table is used to open the gaps between the sliced product. The tape to be used for each product differs. The top table is designed to be easily changed when product dimensions change. The product belt is produced from polyurethane material suitable for food.

TEKNİK ÖZELLİKLER TECHNICAL FEATURES	
VOLTAJ VOLTAGE	380V-3 Faz N Pe 380V-3 Phases N Pe
FREKANS FREQUENCY	50 Hz
ŞASE CHASSIS	AISI304
ELEKTRİK GÜCÜ ELECTRIC POWER	1,5 kW
MOTOR SAYISI NUMBER OF MOTOR	1

**GIYOTİN KESİM MAKİNASI**  
GUILLOTINE CUTTING MACHINE  
MACHINE DE DECOUPE A GUILLOTINE  
МАШИНА ДЛЯ ГИЛЬОТИННОЙ РЕЗКИ  
ماكينة قطع المقصلة

technostar

**ÇİKOLATA TEMPERLEME MAKİNASI**  
CHOCOLATE TEMPERING MACHINE  
MACHINE TEMPEREUSE DE CHOCOLAT  
МАШИНА ДЛЯ ТЕМПЕРИРОВАНИЯ ШОКОЛАДА  
ماكينة درجة حرارة الشوكولاتة

technostar

**ÇİKOLATA KAPLAMA**  
CHOCOLATE ENROBING MACHINE  
ENROBEUSE DE CHOCOLAT  
ШОКОЛАДНОЕ ПОКРЫТИЕ  
طلاء الشوكولاتة



## ÜRÜN ÖZELLİKLERİ

Dilimleme makinasında dilimlenen ürünün boyunu kesebilmek için giyotin kesim makinası kullanılır. Ürünün boyu istenilen ölçülerde hassas bir şekilde ayarlanabilir. Giyotin kesim makinasının girişinde ve çıkışında bulunan bantlar poliüretan malzemeden üretilip gerginlikleri ve akışı pnömatik sistem ile otomatik olarak sağlanır.

## PRODUCT FEATURES

A guillotine cutting machine is used to cut the length of the sliced product in the slicing machine. The size of the product can be precisely adjusted to the desired dimensions. The belts at the entrance and exit of the guillotine cutting machine are produced from polyurethane material and their tension and flow are automatically provided by the pneumatic system.

TEKNİK ÖZELLİKLER TECHNICAL FEATURES	
VOLTAJ VOLTAGE	380V-3 Faz N Pe 380V-3 Phases N Pe
FREKANS FREQUENCY	50 Hz
ŞASE CHASSIS	AISI304
ELEKTRİK GÜCÜ ELECTRIC POWER	4 kW
KAPASİTE CAPACITY	500kg/saat 500kg/hour
MOTOR SAYISI NUMBER OF MOTOR	4

TEKNİK ÖZELLİKLER TECHNICAL FEATURES	
VOLTAJ VOLTAGE	380V-3 Faz N Pe 380V-3 Phases N Pe
FREKANS FREQUENCY	50 Hz
ŞASE CHASSIS	AISI304
ELEKTRİK GÜCÜ ELECTRIC POWER	12 kW
KAPASİTE CAPACITY	250kg/saat 250kg/hour
MOTOR SAYISI NUMBER OF MOTOR	1
HAVA AIR PRESSURE	6 Bar

## ÜRÜN ÖZELLİKLERİ

İyi bir çikolata elde edebilmek için iyi bir temperleme işlemi gerekmektedir. Temperlenen çikolata her türlü kalıplama ya da kaplama uygulaması için ideal yapıdadır. Hatta üstün tasarımımız sayesinde klasik temperleme makinalarından daha yüksek sıcaklıklarda kusursuz temperi yakalar. Bu sayede düşük viskoziteli çikolata ile kaplama ya da dolum makinalarınız çok daha rahat çalışır. Entegre temper kırıcısı sayesinde ilave ekipman yatırımı gerekmeden çalışır.

## PRODUCT FEATURES

A good tempering process is required to obtain a good chocolate. Tempered chocolate is ideal for any molding or coating application. In fact, thanks to our superior design, it achieves the perfect temper at higher temperatures than conventional tempering machines. In this way, your coating or filling machines with low viscosity chocolate work much more easily. Thanks to its integrated temper breaker, it works without the need for additional equipment investment.

## TEKNİK ÖZELLİKLER TECHNICAL FEATURES

VOLTAJ VOLTAGE	380V-3 Faz N Pe 380V-3 Phases N Pe
FREKANS FREQUENCY	50 Hz
ŞASE CHASSIS	AISI304
ELEKTRİK GÜCÜ ELECTRIC POWER	24 kW
KAPASİTE CAPACITY	500kg/saat 500kg/hour
MOTOR SAYISI NUMBER OF MOTOR	5
HAVA AIR PRESSURE	6 Bar

## ÜRÜN ÖZELLİKLERİ

Ürünlerin çikolata kaplama işleminin gerçekleştirilmesine uygun olarak tasarlanmıştır. Ürünün alt, üst veya komple kaplama seçenekleri bulunmaktadır. Tel bantlar tamamen 304 kalite krom-nikel malzemedir. Bant çıkışında üzerindeki dalgalanmayı yok etmek ve fazla çikolatayı hazneye aktarmak için üfleme sistemi mevcuttur.

## PRODUCT FEATURES

It is designed in accordance with the chocolate coating process of the products. The product has bottom, top or complete coating options. Wire bands are completely 304 quality chrome-nickel material. There is a blowing system at the exit of the belt to eliminate the fluctuation on it and to transfer the excess chocolate to the chamber.

**ÇİKOLATA SOĞUTMA TÜNELİ**  
CHOCOLATE COOLING TUNNEL  
TUNNEL DE REFROIDISSEMENT CHOCOLAT  
ТУННЕЛЬ ОХЛАЖДЕНИЯ ШОКОЛАДА  
نفق تبريد الشوكولاتة

technostar

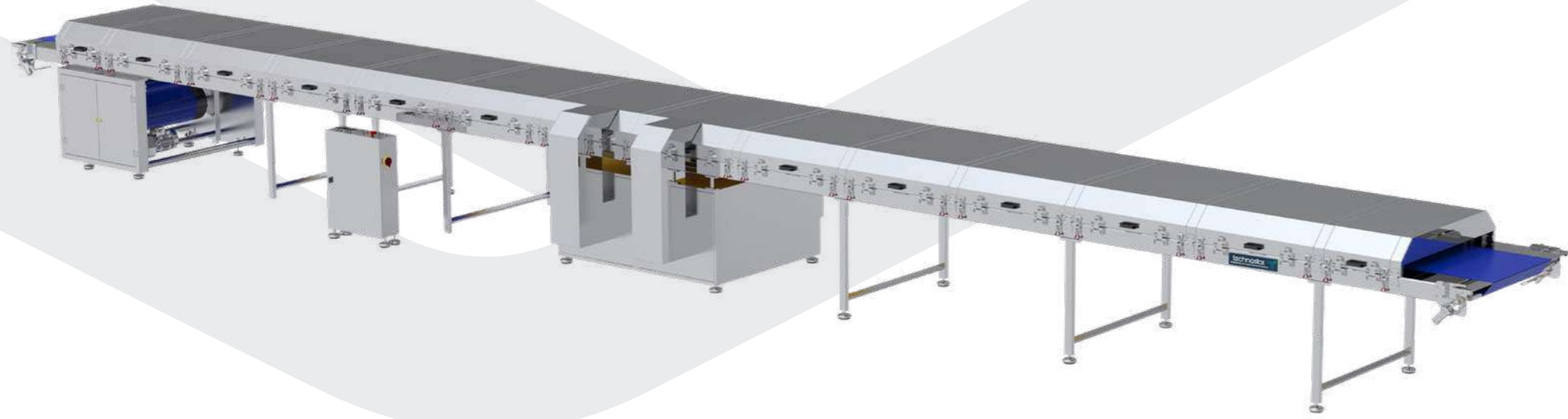

**TEKNİK ÖZELLİKLER**  
TECHNICAL FEATURES

VOLTAJ VOLTAGE	380V-3 Faz N Pe 380V-3 Phases N Pe
FREKANS FREQUENCY	50 Hz
ŞASE CHASSIS	AISI304
ELEKTRİK GÜCÜ ELECTRIC POWER	9 kW
KAPASİTE CAPACITY	500kg/saat 500kg/hour
MOTOR SAYISI NUMBER OF MOTOR	1
HAVA AIR PRESSURE	6 Bar

**ÜRÜN ÖZELLİKLERİ**

Soğutma tüneli içerisine aldığı ürünün sıcaklığını istenilen değerlere düşürmek için kullanılan poliüretan bant ile paslanmaz malzemelerden üretilen bir makinedir. Bant ömrünü uzatan otomatik bant gerdirme sistemi vardır. Soğutma tünelinde bağımsız olarak çalışan çift soğutma sistemi bulunmaktadır. Bu sayede tüneli iki farklı ısı bölgesinde kontrol edebilirsiniz.

**PRODUCT FEATURES**

It is a machine made of stainless materials with a polyurethane belt used to reduce the temperature of the product inside the cooling tunnel to the desired values. There is an automatic belt tensioning system that extends the belt life. There is a double cooling system operating independently in the cooling tunnel. In this way, you can control the tunnel in two different heat zones.



**YUMURTA SOLÜSYON TANKI**  
EGG SOLUTION TANK  
CUVE DE SOLUTION D'OEUF  
БАК ДЛЯ ЯИЧНОГО РАСТВОРА  
خزان محلول البيض

technostar



**ÜRÜN ÖZELLİKLERİ**

Üretilecek olan ürünler için gerekli olan yumurta solüsyonunu hazırlayan ve stoklayan tanktır. Mikser katı haldeki maddeleri ön hazırlama tankında kullanılacak şekilde homojen bir sıvı haline getirir. Hazır yumurta solüsyonunu hazır bekletip istenildiği zaman otomatik olarak ön hazırlamaya gönderir.

**PRODUCT FEATURES**

It is the tank that prepares and stocks the egg solution required for the products to be produced. The mixer turns solid materials into a homogeneous liquid to be used in the pre-preparation tank. It keeps the ready egg solution ready and sends it to pre-preparation automatically when requested.

**TEKNİK ÖZELLİKLER**  
TECHNICAL FEATURES

VOLTAJ VOLTAGE	380V-3 Faz N Pe 380V-3 Phases N Pe
FREKANS FREQUENCY	50 Hz
ŞASE CHASSIS	AISI304
ELEKTRİK GÜCÜ ELECTRIC POWER	10 kW
KAPASİTE CAPACITY	500kg/saat 500kg/hour
MOTOR SAYISI NUMBER OF MOTOR	2

**ÜRÜN ÖZELLİKLERİ**

Kullanılmak istenen miktarda şekeri kazanın içerisine aktarabilmek amacıyla kullanılan helezonlu sistemdir. Kristal şekeri ön hazırlama tankına aktarır. Hazne içerisinde elek mevcuttur. Ürün miktarını belirleyebilmek amacıyla hazne şaseye loadcell bağlantıları ile bağlıdır. İstenilen kapasitelerde üretilebilir.

**PRODUCT FEATURES**

This is a spiral system used to transfer the desired amount of sugar into the boiler. It transfers the crystal sugar to the pre-preparation tank. There is a sieve in the chamber. In order to determine the amount of product, the chamber is connected to the frame with force sensor connections. It can be produced in the desired capacities.



**TEKNİK ÖZELLİKLER**  
TECHNICAL FEATURES

VOLTAJ VOLTAGE	380V-3 Faz N Pe 380V-3 Phases N Pe
FREKANS FREQUENCY	50 Hz
ŞASE CHASSIS	AISI304
ELEKTRİK GÜCÜ ELECTRIC POWER	1,5 kW
KAPASİTE CAPACITY	300kg/saat 300kg/hour
MOTOR SAYISI NUMBER OF MOTOR	1

**DESEN ATMA MAKİNASI(OPSİYONEL)**  
PATTERN THROW MACHINE(OPTIONAL)  
MACHINE A JET DE DESSIN(OPTIONNEL)  
ДЕКОРАТОР (ОПЦИЯ)  
ماكينة النقش (اختياري)

technostar

**GRANÜL DÖKME(OPSİYONEL)**  
GRANULAR POURING(OPTIONAL)  
VERSEMENT GRANULE(OPTIONNEL)  
ГРАНУЛИРОВАННАЯ ЗАЛИВКА (ОПЦИЯ)  
الحبيبات السائبة(اختياري)

**YAĞ ERİTME TANKI**  
FAT MELTING TANK  
CUVE DE FUSION DES GRAISSES  
БАК ДЛ Я ПЛАВКИ МАСЛА  
خزان ذوبان الزيت

technostar

**ÇİKOLATA MUTFAĞI**  
CHOCOLATE KITCHEN

**PSM 500-PUDRA ŞEKERİ DEĞİRMENİ**  
PSM 500- POWDER SUGAR MILL  
PSM 500- MOULIN A SUCRE EN POWDRE  
МЕЛЬНИЦА ДЛ Я САХАРНОЙ ПУДРЫ PSM 500  
مطحنة السكر PSM.500 بودرة



## ÜRÜN ÖZELLİKLERİ

Desen atma makinamız küçük bir dokunuşla kaplama yapılması istenilen ürünlerinizi hem görsel hem de lezzete hitap edecek şekilde zenginleştirir. Desen atma makinası ile çikolata kaplı gofretlerin üzerine çeşitli desenler uygulamak mümkündür. Desen atma makinamızla birçok deseni ürünlerinize kolaylıkla uygulayabilirsiniz.

## PRODUCT FEATURES

Our pattern throwing machine enriches your products, which are desired to be coated with a small touch, in a way that appeals to both visual and taste. It is possible to apply various patterns on chocolate covered wafers with the pattern throwing machine. You can easily apply many patterns to your products with our pattern throwing machine.

TEKNİK ÖZELLİKLER TECHNICAL FEATURES	
VOLTAJ VOLTAGE	380V-3 Faz N Pe 380V-3 Phases N Pe
FREKANS FREQUENCY	50 Hz
ŞASE CHASSIS	AISI304
ELEKTRİK GÜCÜ ELECTRIC POWER	7 kW
KAPASİTE CAPACITY	150kg/saat 150kg/hour
MOTOR SAYISI NUMBER OF MOTOR	1

## ÜRÜN ÖZELLİKLERİ

Ürünlerinizi fındık, hindistan cevizi, susam, granür, nişasta gibi taneli çeşniler ile kaplayabilmeniz için tasarlanmıştır. Serpme işlemi komple yapılabileceği gibi istenen aralık ve genişlikte şerit şeklinde de yapılabilir.

## PRODUCT FEATURES

It is designed to cover your products with granular seasonings such as hazelnut, coconut, sesame, granule, starch. Sprinkling can be done completely, or it can be done in the form of strips in the desired spacing and width.

## TEKNİK VERİLER

- Bant hızı ve üzerindeki serpme kalınlığı ayarlanabilir.
- 620-1800 mm arasında istenilen bant genişliklerinde üretilebilir.
- Granülerin temas ettiği yüzeyler paslanmaz çelikten imal edilmiştir.

## TECHNICAL DATA

- Belt speed and scattering thickness can be adjusted.
- It can be produced in desired belt widths between 620-1800 mm.
- The surfaces that the granules come into contact with are made of stainless steel.



## ÜRÜN ÖZELLİKLERİ

Yağ eritme makinası, çikolata üretiminde kullanılmak amacıyla katı yağların eritilmesi için kullanılır. Hazne içerisinde yağı eritmek için sıcak su dolaştırılan serpantin mevcuttur. Eritilen yağ kullanılmak üzere pompa vasıtası ile çikolata mikserine gönderilir.

## PRODUCT FEATURES

Fat melting machine is used for melting solid fats for use in chocolate production. There is a serpentine in which hot water is circulated to melt the oil in the chamber. The melted oil is sent to the chocolate mixer by means of a pump to be used.

TEKNİK ÖZELLİKLER TECHNICAL FEATURES	
GİRİŞ GÜCÜ INPUT POWER	9 kW
KAPASİTE CAPACITY	400 kg
GERİLİM VOLTAGE	380V - 3 Faz N Pe - 50Hz

## ÜRÜN ÖZELLİKLERİ

Pudra şeker değirmeni, kristal şekeri öğütürerek toz şeker yapmak için tasarlanmıştır. Şeker dövme haznesi AISI 304 paslanmaz çelikten imal edilir ve üzerinde elek sistemi vardır. 30-140 mikron arası incelikte pudra şekeri elde edilir.

## PRODUCT FEATURES

The powdered sugar mill is designed to grind crystal sugar to make granulated sugar. Sugar forging chamber is made of AISI 304 stainless steel and has a sieve system on it. Powdered sugar of 30-140 microns is obtained.

## TEKNİK VERİLER

- Öğütme motor gücü 11 kW ve kayış kasnak sistemine sahiptir.
- Helezon motor güçleri 1,1 ve 0,75 kW' tır.
- Çalışma voltajı 380V, toplam kurulu gücü 13 kW' tır.

## TECHNICAL DATA

- Grinding motor power of 11 kW and a belt and pulley system.
- Spiral motor powers are 1.1 and 0.75 kW.
- Working voltage is 380V, total installed power is 13 kW.



ÖN HAZIRLAMA TANKI  
PREPARATION TANK  
CUVE DE PREPARATION  
ПОДГОТОВИТЕЛЬНЫЙ РЕЗЕРВУАР  
خزان التحضير

technostar

ÇİKOLATA MİKSERİ  
CHOCOLATE MIXER  
MIXEUR A CHOCOLAT  
ШОКОЛАДНЫЙ МИКСЕР  
خلاط الشوكولاتة

ÇİKOLATA STOK TANKI  
CHOCOLATE STOCK TANK  
CUVE DE STOCK DE CHOCOLAT  
РЕЗЕРВУАР ДЛЯ ХРАНЕНИЯ ШОКОЛАДА  
خزان تخزين الشوكولاتة

technostar

ÇİKOLATA SERVİS TANKI  
CHOCOLATE SERVICE TANK  
CUVE DE SERVICE CHOCOLAT  
РЕЗЕРВУАР ДЛЯ СЕРВИСА ШОКОЛАДА  
خزان خدمة الشوكولاتة



### ÜRÜN ÖZELLİKLERİ

Üretilcek olan ürünler için gerekli olan hammaddeleri homojen bir şekilde karıştırıp sıvı hale getiren makinadır. Gövde ısıtma sistemi merkezi sıcak su ile sağlanmaktadır. Tartı ünitesi bulunmaktadır.

### PRODUCT FEATURES

It is a machine that homogeneously mixes and liquefies the raw materials (such as oil, milk powder, sugar, lecithin, aroma, vanilla) required for the products to be produced. Body heating system is provided with central hot water. There is a weighing unit.

### TEKNİK ÖZELLİKLER TECHNICAL FEATURES

VOLTAJ VOLTAGE	380V-3 Faz N Pe 380V-3 Phases N Pe
FREKANS FREQUENCY	50 Hz
ŞASE CHASSIS	AISI304
ELEKTRİK GÜCÜ ELECTRIC POWER	10 kW
KAPASİTE CAPACITY	500kg/saat 500kg/hour
MOTOR SAYISI NUMBER OF MOTOR	2

### ÜRÜN ÖZELLİKLERİ

Çikolata karışımını daha homojen bir yapıya ulaştırmak ve inceltmek amacıyla kullanılan makinadır. Hazırlanan çikolata karışımı pompalar aracılığı ile çikolata stok tankına gönderilir.

### PRODUCT FEATURES

This machine is used to achieve a more homogeneous structure and to thin the chocolate mixture. The prepared chocolate mixture is sent to the chocolate stock tank by means of pumps.

### TEKNİK ÖZELLİKLER TECHNICAL FEATURES

GİRİŞ GÜCÜ INPUT POWER	27 kW
KAPASİTE CAPACITY	500 kg
GERİLİM VOLTAGE	380V – 3 Faz N Pe – 50Hz

### ÜRÜN ÖZELLİKLERİ

Üretilcek olan ürünler için gerekli olan çikolatanın pişirildikten sonra stoklandığı tanktır. Kullanılmak üzere bekletilen çikolatanın homojen yapısı bozulmaması için sürekli olarak karıştırıcı sistemi mevcuttur. Kullanılmak istenildiğinde pompalar vasıtası ile aktarılabilir. Karıştırıcının hız ayarlı, sürekli veya dur / kalk şeklinde karıştırma imkanı bulunmaktadır.

### PRODUCT FEATURES

It is the tank where the chocolate required for the products to be produced is stored after cooking. There is a continuous mixer system in order not to spoil the homogeneous structure of the chocolate that is kept for use. It can be transferred by means of pumps when it is desired to be used. The mixer has the possibility of speed-adjusted, continuous or stop/start mixing.

### TEKNİK ÖZELLİKLER TECHNICAL FEATURES

VOLTAJ VOLTAGE	380V-3 Faz N Pe 380V-3 Phases N Pe
FREKANS FREQUENCY	50 Hz
ŞASE CHASSIS	AISI304
ELEKTRİK GÜCÜ ELECTRIC POWER	10 kW
KAPASİTE CAPACITY	500 kg
MOTOR SAYISI NUMBER OF MOTOR	2

### ÜRÜN ÖZELLİKLERİ

Üretilcek olan ürünler için gerekli olan hammaddenin pişirildikten ve stoklandıktan sonra kullanılmak üzere aktarıldığı tanktır. Ürün kullanılmak istenildiğinde pompalar vasıtası ile pişirme ünitesine aktarılır. Ürün sıcaklığı bu tankta eşanjör ve çiller ile istenilen sıcaklığa ayarlanmaktadır.

### PRODUCT FEATURES

It is the tank where the raw materials required for the products to be produced are transferred to be used after cooking and stocking. When the product is desired to be used, it is transferred to the cooking unit by means of pumps. The product temperature is adjusted to the desired temperature with the heat exchanger and chiller in this tank.

### TEKNİK ÖZELLİKLER TECHNICAL FEATURES

VOLTAJ VOLTAGE	380V-3 Faz N Pe 380V-3 Phases N Pe
FREKANS FREQUENCY	50 Hz
ŞASE CHASSIS	AISI304
ELEKTRİK GÜCÜ ELECTRIC POWER	10 kW
KAPASİTE CAPACITY	500 kg
MOTOR SAYISI NUMBER OF MOTOR	2

ŞURUP ÖN HAZIRLAMA TANKI  
SYRUP PREPARATION TANK  
CUVE DE PREPARATION SIROP  
ПОДГОТОВИТЕЛЬНЫЙ РЕЗЕРВУАР ДЛЯ СИРОПА  
خزان تحضير الشراب

technostar

ŞURUP PIŞİRME TANKI  
SYRUP COOKING TANK  
CUVE DE CUISSON SIROP  
ВАРОЧНЫЙ РЕЗЕРВУАР ДЛЯ СИРОПА  
خزان طبخ شراب

ÇİKOLATA STOK TANKI  
CHOCOLATE STOCK TANK  
CUVE DE STOCK DE CHOCOLAT  
РЕЗЕРВУАР ДЛЯ ХРАНЕНИЯ СИРОПА  
خزان شراب

technostar

MARSHMALLOW JELATİNLEME TANKI  
MARSHMALLOW GELATINING TANK  
CUVE DE GELATINAGE DE MARSHMALLOW  
РЕЗЕРВУАР ДЛЯ ЖЕЛАТИНИЗАЦИИ ЗЕФИРА  
خزان جيلاتين مارشميلو

## MARSHMALLOW MUTFAĞI MARSHMALLOW KITCHEN



### ÜRÜN ÖZELLİKLERİ

Üretilecek olan ürünler için gerekli olan hammaddeleri homojen bir şekilde karıştırıp sıvı hale getiren makinedir. Gövde ısıtma sistemi merkezi sıcak su ile sağlanmaktadır. Tartı ünitesi bulunmaktadır.

### PRODUCT FEATURES

It is a machine that homogeneously mixes and liquefies the raw materials (such as oil, milk powder, sugar, lecithin, aroma, vanilla) required for the products to be produced. Body heating system is provided with central hot water. There is a weighing unit.

TEKNİK ÖZELLİKLER TECHNICAL FEATURES	
VOLTAJ VOLTAGE	380V-3 Faz N Pe 380V-3 Phases N Pe
FREKANS FREQUENCY	50 Hz
ŞASE CHASSIS	AISI304
ELEKTRİK GÜCÜ ELECTRIC POWER	10 kW
KAPASİTE CAPACITY	500kg/saat 500kg/hour
MOTOR SAYISI NUMBER OF MOTOR	2

### ÜRÜN ÖZELLİKLERİ

Üretilecek olan ürünler için gerekli olan hammaddeleri pişiren ve stok tankına aktaran tanktır. Buhar ile pişirme yapar. Pişirme sıcaklığına ulaştığında otomatik olarak işlemi sonlandırır. Sistem sürekli veya kesintisiz ürün işleme yapabilir. Ürünün daha hızlı pişmesi ve yanmaması için özel dizayn edilmiş karıştırıcı ve sıyrıcıları mevcuttur. Sistem sürekli veya kesintili ürün işleme yapabilir.

### PRODUCT FEATURES

It is the tank that cooks the raw materials required for the products to be produced and transfers them to the stock tank. It cooks with steam. It automatically ends the process when it reaches the cooking temperature. The system can perform continuous or uninterrupted product processing. Specially designed mixers and scrapers are available for the product to cook faster and not burn. The system can perform continuous or intermittent product processing.



TEKNİK ÖZELLİKLER TECHNICAL FEATURES	
VOLTAJ VOLTAGE	380V-3 Faz N Pe 380V-3 Phases N Pe
FREKANS FREQUENCY	50 Hz
ŞASE CHASSIS	AISI304
ELEKTRİK GÜCÜ ELECTRIC POWER	13 kW
KAPASİTE CAPACITY	300kg/saat 300kg/hour
MOTOR SAYISI NUMBER OF MOTOR	2
BUHAR BASINCI STEAM PRESSURE	600kPa

Not: Her bir hat için mutfak ekipmanları değişmektedir.  
Note: Kitchen equipment varies for each line

### ÜRÜN ÖZELLİKLERİ

Üretilecek olan ürünler için gerekli olan çikolatanın pişirildikten sonra stoklandığı tanktır. Kullanılmak üzere bekletilen çikolatanın homojen yapısı bozulmaması için sürekli olarak karıştırıcı sistemi mevcuttur. Kullanılmak istenildiğinde pompalar vasıtası ile aktarılabilir. Karıştırıcının hız ayarlı, sürekli veya dur / kalk şeklinde karıştırma imkanı bulunmaktadır.

### PRODUCT FEATURES

It is the tank where the chocolate required for the products to be produced is stored after cooking. There is a continuous mixer system in order not to spoil the homogeneous structure of the chocolate that is kept for use. It can be transferred by means of pumps when it is desired to be used. The mixer has the possibility of speed-adjusted, continuous or stop/start mixing.



TEKNİK ÖZELLİKLER TECHNICAL FEATURES	
VOLTAJ VOLTAGE	380V-3 Faz N Pe 380V-3 Phases N Pe
FREKANS FREQUENCY	50 Hz
ŞASE CHASSIS	AISI304
ELEKTRİK GÜCÜ ELECTRIC POWER	10 kW
KAPASİTE CAPACITY	500 kg
MOTOR SAYISI NUMBER OF MOTOR	2

Not: Her bir hat için mutfak ekipmanları değişmektedir.  
Note: Kitchen equipment varies for each line



### ÜRÜN ÖZELLİKLERİ

Marshmallow için lazım olan şurubun pişirildikten sonra stoklandığı ve jelatinlendiği tanktır. Ürün kullanılmak istenildiğinde pompalar vasıtası ile pişirme ünitesine aktarılır. Homojen yapıyı korumak için içerisinde karıştırıcılar mevcuttur.

### PRODUCT FEATURES

It is the tank where the syrup needed for marshmallow is stored and gelatinized after cooking. When the product is desired to be used, it is transferred to the cooking unit by means of pumps. There are mixers inside to maintain the homogeneous structure.

TEKNİK ÖZELLİKLER TECHNICAL FEATURES	
VOLTAJ VOLTAGE	380V-3 Faz N Pe 380V-3 Phases N Pe
FREKANS FREQUENCY	50 Hz
ŞASE CHASSIS	AISI304
ELEKTRİK GÜCÜ ELECTRIC POWER	10 kW
KAPASİTE CAPACITY	500 kg
MOTOR SAYISI NUMBER OF MOTOR	2

technostarmachine.com

technostarmachine.com



**ŞURUP SERVİS TANKI**  
SYRUP SERVICE TANK  
CUVE DE SERVICE SIROP  
РЕЗЕРВУАР ДЛЯ СЕРВИСА СИРОПА  
خزان خدمة شراب

technostar

**TURBO MİKSER**  
TURBO MIXER  
TURBO MIXEUR  
ТУРБОМІКСЕР  
خلاط تيربو

**ÇİRPİCİ MİKSER**  
WHISK MIXER  
MIXEUR FOUETEUR  
СМЕСИТЕЛЬ ДЛЯ ВЗБИВАНИЯ  
بيشر خلط

technostar

**SÜT SOLÜSYON TANKI**  
MILK SOLUTION TANK  
CUVE SOLUTION DE LAIT  
БАҚДЛЯ МОЛОЧНОГО РАСТВОРА  
خزان محلول الحليب

## ÜRÜN ÖZELLİKLERİ

Üretilecek olan ürünler için gerekli olan hammaddenin pişirildikten ve stoklandıktan sonra kullanılmak üzere aktarıldığı tanktır. Ürün kullanılmak istenildiğinde pompalar vasıtası ile pişirme ünitesine aktarılır. Ürün sıcaklığı bu tankta eşanjör ve çiller ile istenilen sıcaklığa ayarlanmaktadır.

## PRODUCT FEATURES

It is the tank where the raw materials required for the products to be produced are transferred to be used after cooking and stocking. When the product is desired to be used, it is transferred to the cooking unit by means of pumps. The product temperature is adjusted to the desired temperature with the heat exchanger and chiller in this tank.

TEKNİK ÖZELLİKLER TECHNICAL FEATURES	
VOLTAJ VOLTAGE	380V-3 Faz N Pe 380V-3 Phases N Pe
FREKANS FREQUENCY	50 Hz
ŞASE CHASSIS	AISI304
ELEKTRİK GÜCÜ ELECTRIC POWER	10 kW
KAPASİTE CAPACITY	500 kg
MOTOR SAYISI NUMBER OF MOTOR	2

## ÜRÜN ÖZELLİKLERİ

Max. soğutma veya ısıtma elde edilebilmesi için Turbo Mikserin hem rotoru hem de statoru su cidarlı olarak tasarlanmış ve imal edilmiştir. Mikser çıkışında ise ürünün basıncını düşürmek ve havalandırılmış hamuru istenen basınçta bir sonraki üniteye aktarmak üzere tasarlanmış karşı basınç ünitesi mevcuttur. Mikser aktif konuma geldikten sonra yapılması gereken tek işlem, kapasiteyi ve çıkıştaki ürün yoğunluğunu dokunmatik ekrandan girmektir.

## PRODUCT FEATURES

Max. In order to achieve cooling or heating, both the rotor and the stator of the Turbo Mixer are designed and manufactured as water-walled. At the mixer outlet, there is a counter pressure unit designed to reduce the pressure of the product and transfer the aerated dough to the next unit at the desired pressure. The only thing that needs to be done after the mixer is activated is to enter the capacity and the product density at the output from the touch screen.



TEKNİK ÖZELLİKLER TECHNICAL FEATURES	
VOLTAJ VOLTAGE	380V-3 Faz N Pe 380V-3 Phases N Pe
FREKANS FREQUENCY	50 Hz
ŞASE CHASSIS	AISI304
ELEKTRİK GÜCÜ ELECTRIC POWER	8 kW
KAPASİTE CAPACITY	500kg/saat 500kg/hour
MOTOR SAYISI NUMBER OF MOTOR	1
HAVA AIR PRESSURE	6 Bar

## ÜRÜN ÖZELLİKLERİ

Üretilecek olan ürünler için gerekli olan çikolatanın pişirildikten sonra stoklandığı tanktır. Kullanılmak üzere bekletilen çikolatanın homojen yapısı bozulmaması için sürekli olarak karıştırıcı sistemi mevcuttur. Kullanılmak istenildiğinde pompalar vasıtası ile aktarılabilir. Karıştırıcının hız ayarlı, sürekli veya dur / kalk şeklinde karıştırma imkânı bulunmaktadır.

## PRODUCT FEATURES

It is the tank where the syrup required for the products to be produced is mixed. When the product is desired to be used, it is transferred to the cooking unit by means of pumps. The mixer has the possibility of speed-adjusted, continuous or stop/start mixing.

TEKNİK ÖZELLİKLER TECHNICAL FEATURES	
VOLTAJ VOLTAGE	380V-3 Faz N Pe 380V-3 Phases N Pe
FREKANS FREQUENCY	50 Hz
ŞASE CHASSIS	AISI304
ELEKTRİK GÜCÜ ELECTRIC POWER	2,5 kW
KAPASİTE CAPACITY	70 kg
MOTOR SAYISI NUMBER OF MOTOR	2



TEKNİK ÖZELLİKLER TECHNICAL FEATURES	
VOLTAJ VOLTAGE	380V-3 Faz N Pe 380V-3 Phases N Pe
FREKANS FREQUENCY	50 Hz
ŞASE CHASSIS	AISI304
ELEKTRİK GÜCÜ ELECTRIC POWER	10 kW
KAPASİTE CAPACITY	500 kg
MOTOR SAYISI NUMBER OF MOTOR	2



## ÜRÜN ÖZELLİKLERİ

Üretilecek olan ürünler için gerekli olan süt solüsyonunu hazırlayan ve stoklayan tanktır. Mikser katı haldeki maddeleri (şeker, glikoz, süt tozu) ön hazırlama tankında kullanılacak şekilde homojen bir sıvı haline getirir. Hazır süt solüsyonunu hazır bekletip istenildiği zaman otomatik olarak ön hazırlamaya gönderir.

## PRODUCT FEATURES

It is the tank that prepares and stocks the milk solution required for the products to be produced. The mixer turns solid materials (sugar, glucose, milk powder) into a homogeneous liquid to be used in the pre-preparation tank. It keeps the ready milk solution ready and sends it to pre-preparation automatically when requested.

DEPOZİTÖR(OKS)  
DEPOSITOR  
DEPOSITEUR  
ДЕПОЗИТОР(ОКС)  
(OKS) المودع

technostar



### ÜRÜN ÖZELLİKLERİ

Sert veya yumuşak kek, muhtelif ebatlardaki bisküviler ve kurabiyeler ile çalışabilen, marshmallow, karamel, reçel, krema basabilen, müşteri isteğine göre dolgulu marshmallow veya çift renkli krema ile çalışabilen, magazin ya da fırından direkt beslemeli çalışmaktadır. Magazin beslemesi sayesinde ürün değişimi kolay ve düşük maliyetlidir. Tek bir hat ile çeşitli ürünler yapabilme imkânı sunması sebebiyle müşterilerimiz için ideal bir makinadır.

### TEKNİK VERİLER

- Maksimum 60 sıra/dakika hıza kadar sandviçleme yapar.
- Ürün temas yüzeyleri paslanmaz malzemeden üretilmiştir.

### PRODUCT FEATURES

It can work with hard or soft cakes, biscuits and cookies in various sizes, can press marshmallows, caramel, jam, cream, can work with filled marshmallows or double-colored cream according to the customer's request, and is fed directly from the magazine or oven. Thanks to the magazine feeding, product change is easy and cost-effective. It is an ideal machine for our customers as it offers the opportunity to produce various products with a single line.

### TECHNICAL DATA

- It sandwiches up to a maximum speed of 60 rows/minute.
- Product contact surfaces are made of stainless material.

technostar®  
technostarmachine.com

**technostar**

**GIDA VE PAKETLEME MAKİNALARI**  
FOOD PROCESSING AND PACKAGING MACHINERY



Cep: +90 (531) 365 58 40  
Tel: +90 (386) 272 11 11  
Fax: +90 (386) 272 11 13



[technostarmachine.com](http://technostarmachine.com)  
[info@technostarmachine.com](mailto:info@technostarmachine.com)



Güldiken OSB. Mah. OSB Ahi Evran  
Bulvarı No:1 Kırşehir/TÜRKİYE



/technostarmachine

